

EN TRANSLATION OF THE ORIGINAL INSTALLATION AND OPERATING MANUAL

Swing Gate Operator

twist M

twist ML



Download the current manual:



Congratulations on your purchase of a product of **SOMMER Antriebs- und Funktechnik GmbH**. This product has been developed and manufactured under high standards of quality and with reference to ISO 9001. Our passion for the product is just as important to us as the needs and requirements of our customers. We place particular emphasis on the safety and reliability of our products.

Read this installation and operating manual carefully and follow all instructions.

This will ensure that you can install and operate the product safely and optimally. If you have any questions, please contact your specialist retailer or installer. All our products are intended for use by persons of all genders, even where this is not specifically stated.

Warranty

The warranty complies with statutory requirements. The contact person for warranties is the qualified dealer. The warranty is only valid in the country in which the operator was purchased. There is no warranty for consumables such as batteries, accumulators and fuses as well as light bulbs. This also applies for wear parts. The operator is only designed for a limited frequency of use. More frequent use leads to increased wear.

Contact data

If you require after-sales service, spare parts or accessories, please contact your qualified specialist retailer or installer.

www.sommer.eu/de/kundendienst.html

Copyright and proprietary rights

The manufacturer retains the copyright for this Installation and Operating manual. No part of this installation and operating manual may be reproduced in any form without the written permission of **SOMMER Antriebs- und Funktechnik GmbH** or processed, copied, or distributed using electronic systems. Violations of the specifications above will lead to claims for damages. All brands mentioned in this Installation and Operating Manual are the property of their respective manufacturer and hereby recognised as such.

1. About this Installation and Operating Manual.....	5
1.1 Storage and circulation of the Installation and Operating Manual.....	5
1.2 Important for translations	5
1.3 Description of the product type	5
1.4 Target groups of the Installation and Operating Manual	5
1.5 Explanation of symbols and notes	5
1.6 Special warning symbols and mandatory signs	6
1.7 Information regarding the depiction of text.....	7
1.8 Intended use of the operator	7
1.9 Improper use of the operator.....	7
1.10 Qualifications of personnel.....	8
Qualified specialist for installation, commissioning and disassembly	8
Instructing the user and handover of documents	8
1.11 Information for the user	8
2. General safety instructions.....	9
2.1 Basic safety instructions for operation	9
2.2 Additional safety information for the radio remote control.....	9
2.3 Notes and information on operation and remote control	10
3. Description of function and product.....	11
3.1 The operator and its mode of operation.....	11
3.2 Operator installation position.....	12
3.3 Safety equipment	12
3.4 Product designation	12
3.5 Explanation of terms used.....	12
Left gate/right gate	12
Active leaf	12
Inactive leaf.....	12
Combined operation.....	12
3.6 Scope of delivery.....	13
3.7 Technical data.....	13
Permitted gate leaf dimensions.....	13
Infill.....	13
With inclined gates.....	13
3.8 Dimensions, twist M (dimensions in mm)	14
3.9 Dimensions, twist ML (dimensions in mm)	14
3.10 Connection options	15

Table of contents

4. Installation	16	6.3	Adjusting the force tolerance.....	33
4.1	Required tools and personal protective equipment		Adjusting or checking the force tolerance	33
4.2	Important notes and information	6.4	Preparing continuous operation	33
4.3	Preparing for installation	6.5	Preparing for programming	34
	Requirements for installation	6.6	Enabling continuous operation.....	34
	Removal of actuation parts and unsuitable components	6.7	Performing programming run	34
	Check the existing gate mechanism and installation posts		Detecting faulty programming runs	35
4.4	A/B dimension tables (reference values)	6.8	Resetting the control unit	35
4.5	Fittings.....			
	Steel posts	7. Connections and functions of the control unit	36	
	Brick or concrete pillars.....	7.1	DIP switch	36
	Post/pillar fitting (dimensions in mm)		Overview of the setting options for the DIP switches	36
	Gate leaf fitting (dimensions in mm)	7.2	Automatic closing	37
	Timber post fittings (dimensions in mm)		Fully automatic closing function	37
	Special fittings for internal rotation points		Shortened hold open time.....	37
	Deviation of post fittings.....		Semi-automatic closing function	37
4.6	Installing the operator.....	7.3	Connecting accessories	38
	Observe spare cable.....		Connecting safety devices	38
4.7	Opening/closing the control unit housing		Connecting a 4-wire photocell.....	38
4.8	Installing the control unit		Connecting a warning light (DC 24 V).....	39
4.9	Removing/fitting the cover.....		Connecting an external device.....	39
	Removing the cover		Connecting a floating relay contact.....	39
	Fitting the cover		Connecting an electric lock (DC 24 V)	40
4.10	Locking and unlocking the operator		Attaching connecting cable set (7 m).....	40
	Unlocking the operator.....		Connecting a button.....	41
	Locking the operator		Connecting a key switch	41
	Emergency release by Bowden cable.....		Connecting an accumulator	42
4.11	Connecting operators to the control unit	7.4	Operator lighting (LED)	43
	Gate opening inwards (1-/2-leaf)		LED lighting in the lower housing section	43
	Gate opening outwards (1-/2-leaf)		Sealing plug in the lower housing section.....	43
5. Electrical connection.....	26	7.5	Connections of the motor PCB.....	43
5.1	Mains connection	8. Radio remote control.....	44	
	Connecting the main switch	8.1	Installing the radio receiver	44
5.2	Circuit board of the control unit		Slot for SOMup4 S2 on the circuit board	44
6. Initial operation	31	8.2	Explanation of display and buttons, SOMup4 S2..	44
6.1	Important notes and information	8.3	Explanation of the radio channels.....	44
6.2	Adjusting the end positions	8.4	Selection of the radio channels	44
	1. Setting the "Gate AUF/open" end position	8.5	Programming the transmitter.....	44
	2. Setting "Gate ZU/close" end position	8.6	Cancelling programming mode	45
		8.7	Deleting a transmitter from the radio channel	45
		8.8	Deleting a transmitter from the radio receiver	45
		8.9	Deleting a radio channel in the receiver.....	45

Table of contents

8.10	Delete all radio channels in the receiver	45	13. Taking out of operation, disassembly, storage and disposal	60	
8.11	Programming by radio (HFL).....	46	13.1	Important notes and information	60
	Function	46	13.2	Taking out of operation and disassembly.....	60
	Procedure	46	13.3	Storage.....	60
	Operation	46	13.4	Disposal	61
8.12	Information on Memo	46	14. Brief instructions for installation.....	62	
	Installing the Memo.....	46	15. Connection diagrams and functions of the DIP switches	66	
8.13	Antenna connections.....	47		Overview of the setting options for the DIP switches	66
	Jumper (slots)	47		Connection diagram.....	67
	External antenna.....	47	16. Declarations of Conformity	68	
9. Function test – final test – handover	48		16.1	EC Declaration of Incorporation	68
9.1	Checking the obstacle detection	48	16.2	Simplified EU Declaration of Conformity for radio systems.....	68
	Obstacle detection by photocell.....	48	16.3	UKCA declaration of incorporation.....	69
9.2	Checking the force setting.....	48	16.4	UKCA declaration of conformity for radio systems.....	69
9.3	Handover of the gate system	49			
10. Operation	50				
10.1	Important notes and information	50			
	Normal mode	50			
	Summer mode – winter mode.....	50			
10.2	Operating modes of gate movement.....	51			
10.3	Overview of gate movements opening and closing gate	51			
	Requirements.....	51			
10.4	Obstacle detection	52			
10.5	In the event of a power failure.....	52			
	Emergency release in the event of power failure	52			
	Battery operation in the event of a power failure	52			
10.6	Function of the emergency release.....	52			
	Unlocking the operator.....	53			
	Locking the operator	53			
11. Maintenance and care	54				
11.1	Important notes and information	54			
11.2	Maintenance schedule	54			
11.3	Care	55			
	Cleaning the operator	55			
	Clean the photocell	55			
12. Troubleshooting	56				
12.1	Important notes and information	56			
12.2	Preparing for troubleshooting.....	56			
12.3	Troubleshooting table.....	57			

1. About this Installation and Operating Manual

1.1 Storage and circulation of the Installation and Operating Manual

Read this Installation and Operating Manual carefully and completely before installation, commissioning and operation and also before removal. Observe all warnings and safety instructions.

Keep this Installation and Operating Manual accessible to all users at all times at the place of use. A replacement installation and operating manual can be downloaded from **SOMMER** at:

www.sommer.eu

In the event of transfer or resale of the operator to third parties, the following documents must be passed on to the new owner:

- EC Declaration of Conformity
- handover protocol and inspection book
- this Installation and Operating Manual
- proof of regular maintenance, testing and care
- documents recording retrofitting and repairs

1.2 Important for translations

The original installation and operating manual was written in German. The other available languages are translations of the German version.

You can get the original installation and operating manual by scanning the QR code.



<https://som4.me/orig-twist-M-ML-reva>

For other language versions, see:

www.sommer.eu

1.3 Description of the product type

The operator has been constructed according to state-of-the-art technology and recognised technical regulations and is subject to the Machinery Directive 2006/42/EC.

The operator is fitted with a radio receiver. Optionally available accessories are also described. The version can vary depending on the type. This means the use of accessories can vary.

1.4 Target groups of the Installation and Operating Manual

The installation and operating manual must be read and observed by everyone assigned with one of the following tasks or using the device:

- unloading and in-house transport
- unpacking and installation
- Initial operation
- setting
- usage
- maintenance, testing and care
- troubleshooting and repairs
- disassembly and disposal

1.5 Explanation of symbols and notes

The warnings in this installation and operating manual are structured as follows.

Signal word



Hazard symbol

Type and source of hazard.

Consequences of the hazard.

- ▶ Preventing/avoiding the hazard.

The hazard symbol indicates the hazard. The signal word is linked to a hazard symbol. The hazard is classified into three classes depending on its danger:

DANGER

WARNING

CAUTION

There are three different classifications of hazards.

DANGER



Describes an immediate danger that leads to serious injury or death.

Describes the consequences of the danger to you or other persons.

- ▶ Follow the instructions for avoiding or preventing the danger.

WARNING



Describes a potential danger that may lead to fatal or serious injury.

Describes the possible consequences of the danger to you or other persons.

- ▶ Follow the instructions for avoiding or preventing the danger.

1. About this Installation and Operating Manual

⚠ CAUTION



Describes a potential danger of a hazardous situation.

Describes the possible consequences of the danger to you or other persons.

- ▶ Follow the instructions for avoiding or preventing the danger.

The following symbols are used for notes and information:

➔ NOTE

- Describes additional information and useful notes for correct use of the operator without endangering persons. If it is not observed, property damage or faults in the operator or gate may occur.

i INFORMATION

- Describes additional information and useful tips. Functions for optimum usage of the operator are described.

The following symbols are used in the figures and text.



Continue reading the Installation and Operating Manual for more information.



Trained electrician (required for installation)



Trained mechanic (required for installation)



Disconnect the operator from the voltage supply



Connect the operator to the voltage supply



Factory setting, as-delivered state depending on version



Connection via SOMlink to a WiFi-enabled device



Setting options via DIP switches



Operator components must be disposed of properly



Phillips screwdriver



Flat head screwdriver



Metal drill



Masonry drill



Thread cutter



Open-end wrench



Ratchet wrench



Drilling depth



Audible engaging or clicking noise

1.6 Special warning symbols and mandatory signs

To specify the source of danger more precisely, the following symbols are used together with the above-mentioned hazard symbols and signal words. Follow the instructions to prevent a potential hazard.



Danger due to electric current!



Danger of crushing and shearing!

Applies to 1-leaf gates

Applies to 2-leaf gates



Danger of tripping and falling!



Danger due to hot parts!



Danger due to optical radiation!



Risk of injury to feet!



The following mandatory signs are used for the respective actions. The requirements described must be complied with.



Wear personal safety glasses



Wear personal face protection



Wear a personal safety helmet



Wear personal protective clothing



Wear personal safety gloves



Wear personal safety shoes

1. About this Installation and Operating Manual

1.7 Information regarding the depiction of text

1. Stands for directions for an action

⇒ Stands for the results of the action

✓ **Stands for successful completion of an action**

Lists are shown as a list of actions:

- List 1
- List 2

1, A Item number in the figure refers to a number in the text.

Important text items, for example in directions for actions, are emphasised in **bold** type.

References to other chapters or sections are in **bold** type and set in “**quotation marks**”.

1.8 Intended use of the operator

The operator is designed exclusively for opening and closing 1- and 2-leaf swing gate installations. Any other use does not constitute intended use.

The manufacturer accepts no liability for damage resulting from use other than intended use. The user bears the sole responsibility for any risk involved. It also voids the warranty.

Any changes to the operator must be made with original accessories from **SOMMER** only and only to the extent described.

For more information on accessories, see:



<https://downloads.sommer.eu/>

Gates automated with this operator must comply with all valid international and domestic standards, directives and regulations in their currently valid version. These include EN 12453, EN 12604, EN 12605 and EN 13241.

The operator may only be used:

- with DSTA-24 control unit
- with gate leaves which are stable and resistant to warping. Gate leaves must not bend or twist when opening and closing.



<https://som4.me/cgdo>

- if a correct Declaration of Conformity has been issued for the gate system
- if the CE mark/UKCA mark and the type plate for the gate system have been attached
- if the handover protocol and the inspection book have been completed and are available
- if the installation and operating manuals for the operator and the gate are present
- as specified in this Installation and Operating Manual
- in good technical condition
- with attention to safety and hazards by trained users.

After installation of the operator, the person responsible for the installation of the operator **must** complete an EC Declaration of Conformity for the gate system in accordance with Machinery Directive 2006/42/EC and apply the CE mark/UKCA mark and a type plate to the gate system. This also applies if the operator is retrofitted to a manually operated gate. In addition, a handover protocol and an inspection book **must** be completed.

The following are available:

- EC Declaration of Conformity
- handover protocol for the operator



<https://som4.me/konform>

1.9 Improper use of the operator

Any other use or additional use that has not been described in Chapter 1.8 constitutes improper use. The user bears the sole responsibility for any risk involved.

The manufacturer's warranty will be voided by:

- damage caused by other use and improper use
- use with defective parts (unauthorised modifications to the gate)
- unauthorised modifications to the operator
- modifications and non-approved programming of the operator and its components
- operation with 2x twist M/ML on one leaf is prohibited

The gate must not be part of a fire protection system, an escape route or an emergency exit that automatically closes the gate in the event of fire.

Installation of the operator will prevent automatic closing.

Observe the local building regulations.

The operator may not be used in:

- areas with explosion hazard
- very salty air
- aggressive atmosphere, including chlorine

1. About this Installation and Operating Manual

1.10 Qualifications of personnel

Qualified specialist for installation, commissioning and disassembly

This installation and operating manual **must** be read and complied with by a **qualified specialist** who installs or performs maintenance on the operator.

Work on the electrical system and live parts must be performed by a **trained electrician** in accordance with EN 50110-1.

The installation, initial operation and disassembly of the operator may only be performed by a qualified specialist. A qualified specialist is a person commissioned by the installer.

The qualified specialist must be familiar with the following standards:

- EN 13241 Doors and gates – Product standard
- EN 12604 Doors and gates – Mechanical aspects –
- EN 12605 Requirements and test methods
- EN 12453 Safety in use of power-operated doors

When all work has been completed, the **qualified specialist** must:

- issue an EC Declaration of Conformity
- attach the CE mark/UKCA mark and the type plate to the gate system

Instructing the user and handover of documents

The **qualified specialist** must instruct the user:

- on the operation of the operator and its dangers
- on the handling of the manual emergency release
- on regular maintenance, testing and care which the user can carry out

The **qualified specialist** must inform the user about which work may only be carried out by a qualified specialist:

- installation of accessories
- settings
- regular maintenance, testing and care
- troubleshooting

1.11 Information for the user

The user **must** ensure that the CE mark/UKCA mark and the type plate have been attached to the gate system.

The following documents for the gate system must be handed over to the user:

- correct Declaration of Conformity
- handover protocol and inspection book
- the installation and operating manuals for the operator and the gate

The user is responsible for:

- keeping this Installation and Operating Manual accessible at all times at the place of use
- the intended use of the operator
- ensuring that the operator is in good condition
- instructing all users how to use the operator, the hazards involved and in the operation of the emergency release
- operation
- regular maintenance, testing and care
- troubleshooting

The operator must not be used by persons with restricted physical, sensory or mental capacity or who lack experience and knowledge. All users must be specially instructed and have read and understood the Installation and Operating Manual.

Children must never play with or use the operator, even under supervision. Children must be kept clear of the operator. Handheld transmitters or other command devices must never be given to children. Handheld transmitters must be safely stored and protected against unintended and unauthorised use.

The user must observe the accident prevention regulations and the applicable standards. The guideline "Technical regulations for workplaces ASR A1.7" of the German committee for workplaces (ASTA) is applicable for commercial use. The guidelines described must be observed and complied with. In other countries, the user **must** comply with the applicable national regulations.

2. General safety instructions

2.1 Basic safety instructions for operation

Follow the basic safety instructions listed below.

The control unit must not be used by persons with restricted physical, sensory or mental capacity or who lack experience and knowledge. All users must be specially instructed and have read and understood the installation and operating instructions.

Persons under the influence of drugs, alcohol, or medications that can influence their ability to react may not work on the control unit. Children must never play with or use the control unit, even under supervision. Children must be kept clear of the control unit. Handheld transmitters or other command devices must never be given to children. Handheld transmitters must be safely stored and protected against unintended and unauthorised use.

Danger if not observed!

Serious injury or death may result if safety instructions are not observed.

- ▶ It is imperative to comply with all safety instructions!

Danger due to electric current!

Contact with live parts may result in electric current flowing through the body. Electric shock, burns, or death may result.

- ▶ Installation, testing and replacement of electrical components must be carried out by a **trained electrician**.
- ▶ Before performing work on the operator, it must be disconnected from the power supply.
- ▶ If an accumulator is connected, disconnect it from the control unit.
- ▶ Check that the operator is not live.
- ▶ Secure the operator against being switched back on.

Danger due to use of the operator with incorrect settings or when it is in need of repair!

If the operator is used despite incorrect settings or if it is in need of repair, severe injury or death may result.

- ▶ The control unit may only be used with the required settings and in the proper condition.
- ▶ Have faults repaired professionally without delay.

Danger caused by hazardous substances!

Improper storage, use or disposal of accumulators, batteries and operator components pose a risk to the health of humans and animals. Serious injury or death may result.

- ▶ Accumulators and batteries must be stored out of the reach of children and animals.
- ▶ Keep batteries and accumulators away from chemical and thermal influences.
- ▶ Do not recharge batteries and defective accumulators.
- ▶ All components of the operator, including old accumulators and batteries, must be disposed of correctly and not with household waste.

Danger of crushing and shearing!

If the gate moves and there are persons or animals in the movement area, crushing and shearing injuries may be caused by the mechanism and safety edges of the gate.

- ▶ Only use the operator when you have a direct view of the gate.
- ▶ All danger zones must be visible during the entire gate operation.
- ▶ Always keep the moving gate in sight.
- ▶ Keep persons and animals clear of the range of movement of the gate.
- ▶ Do not drive through the gate until it has opened completely.
- ▶ Store the handheld transmitter so that unauthorised or accidental operation, e.g., by children or animals, is impossible.
- ▶ Never stand in the opened gate.

Danger due to projecting parts!

Parts must not project into public roads or footpaths. This also applies while the gate is moving.

Persons and animals may be seriously injured.

- ▶ Keep public roads and footpaths clear of projecting parts.

Danger caused by voltage peaks!

Voltage peaks, e.g. from welding machines, can destroy the control unit.

- ▶ Do not connect the control unit to the power supply until all installation work has been completed.

Danger of tripping and falling!

Unsafely positioned parts such as packaging, operator parts or tools may cause persons to trip or fall.

- ▶ Keep the installation area free of unnecessary items.
- ▶ Place all parts where no-one is likely to trip or fall over them.
- ▶ The general workplace guidelines must be observed.

Danger due to optical radiation!

Looking into the beam of a bright LED for prolonged periods can cause temporary irritation of the eyes. Serious or fatal accidents can occur as a result.

- ▶ Never look directly into the LED.

Risk of eye injury!

Chips flying when drilling may cause serious injuries to eyes and hands.

- ▶ Wear safety glasses.

Risk of hand injury!

Rough metal parts may cause abrasions and cuts when picked up or touched.

- ▶ Wear your personal safety gloves.

Risk of foot injury!

Falling parts can cause foot injuries.

- ▶ Wear safety shoes.

2. General safety instructions

2.2 Additional safety information for the radio remote control

Follow the basic safety instructions listed below.

Danger of crushing and shearing!

If the gate is not visible and the radio control is operated, crushing and shearing injuries to persons or animals may be caused by the mechanism and safety edges of the gate.

- ▶ In particular when operating control elements such as the radio remote control, all danger zones must be visible during the entire gate operation.
- ▶ Always keep the moving gate in sight.
- ▶ Keep persons and animals clear of the range of movement of the gate.
- ▶ Never put your hand near the gate when it is moving or near moving parts.
- ▶ Do not drive through the gate until it has opened completely.
- ▶ Store the handheld transmitter so that unauthorised or accidental operation, e.g., by children or animals, is impossible.
- ▶ Never stand in the opened gate.

2.3 Notes and information on operation and remote control

The user of the radio system is not protected against interference due to other telecommunications equipment or devices. This includes radio-controlled systems that are licensed to operate in the same frequency range. If significant interference occurs, the user **must** contact the appropriate telecommunications office which has radio interference measuring equipment or radio location equipment.

NOTE

- If the gate is not in view and the radio remote control is actuated, objects in the movement area of the gate may be jammed and damaged.

Objects must not be in the range of movement of the gate.

Only use the operator if you have a direct view of the gate.

INFORMATION



- Operator components that have been taken out of service as well as old accumulators and batteries must not be disposed of with household waste. Components which are no longer in use, old accumulators and batteries must be disposed of properly. You must observe the local and national regulations here.

3. Description of function and product

3.1 The operator and its mode of operation

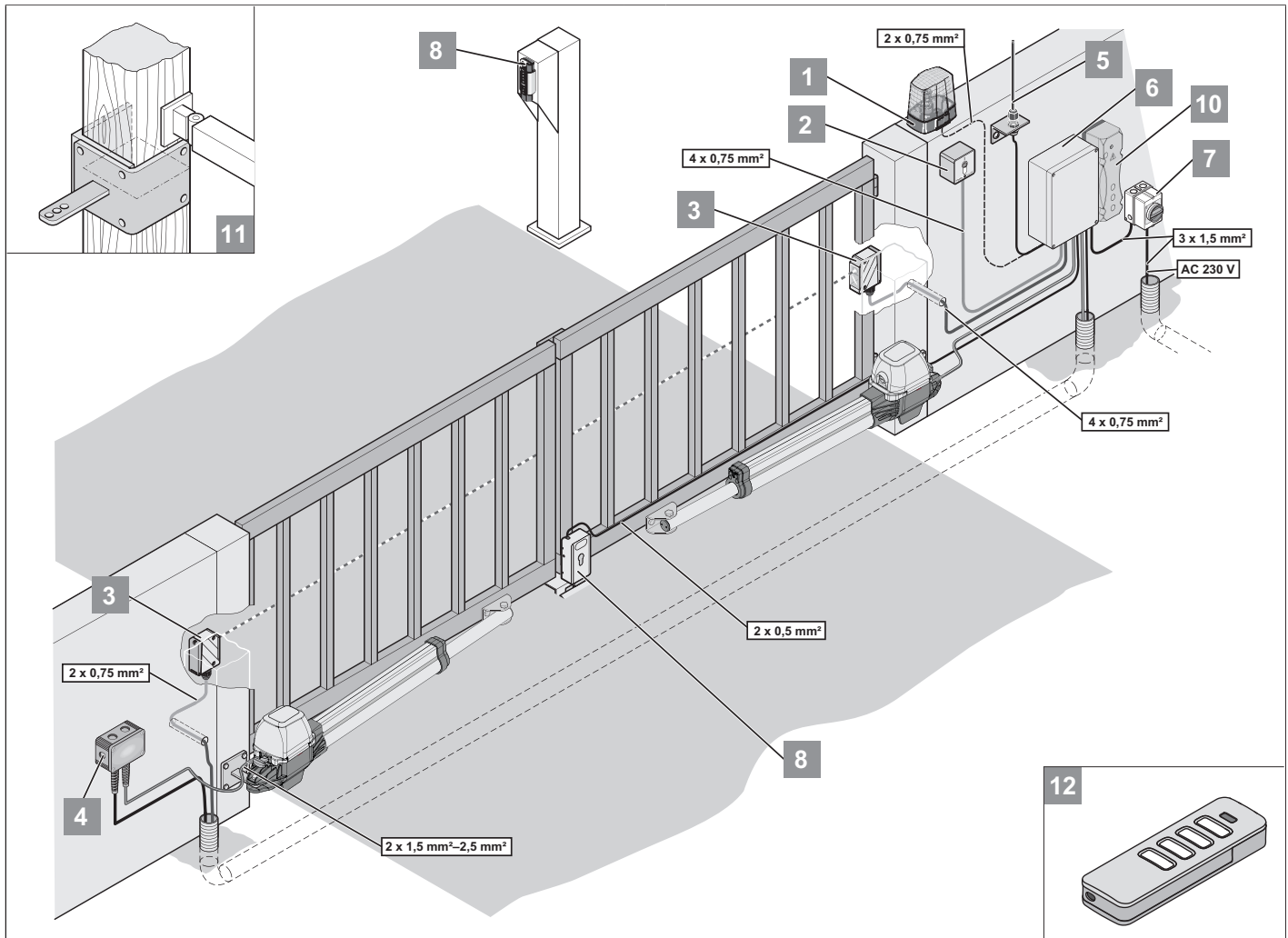

Fig. Gate structure with operator, using the example of a 2-leaf gate

1	Warning light DC 24 V/25 W
2	Key switch (1- or 2-contact)
3	Photocell
4	Connecting cable set 7 m (IP67)
5	External antenna (including cable)
6	Main switch (lockable)
7	Control unit
8	Electric lock DC 24 V
9	Telecodey
10	Accu 2.2
11	Timber post fittings
12	Transmitter

1- and 2-leaf swing gates can be operated with the electrically powered operator and the separate control unit. Optionally available accessories make it possible to adapt the operators to special characteristics of these gates. The operator can be controlled, for example, via a handheld transmitter.

With 2-leaf gates, settings in the control unit ensure compliance with a certain order when opening or closing the gate leaves.

The operator is delivered with accessories such as a handheld transmitter. The set for 2-leaf gates does **not** contain a connection cable for the control unit to the second operator.

➔ NOTE

- Other pulse transmitters are: Handheld transmitters, Telecodeys, wireless wall buttons and key switches.
- For transmitters, Telecodey or interior radio push-buttons, there is no need to install a connecting line to the operator.

3. Description of function and product

3.2 Operator installation position

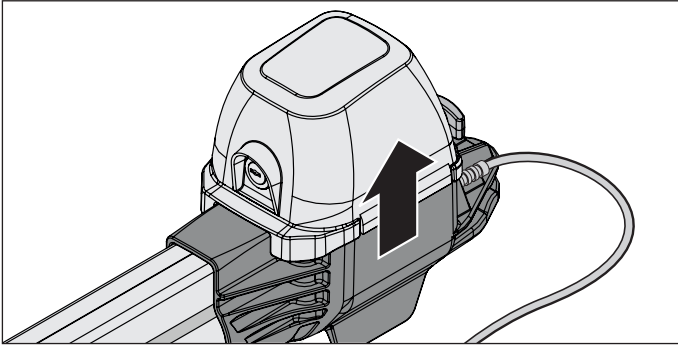

Fig. Example, 1-leaf gate

1. Install operator horizontally. Note installation position of the motor – it **must** always point upwards.

3.3 Safety equipment

The operator stops and reverses slightly if it encounters an obstacle. This prevents injury and damage to property. The gate will be partially or completely opened, depending on the setting.

If the power fails, the gate can be opened from the inside using the emergency release handle or from the outside with a Bowden wire.

See also Chapter “10.5 In the event of a power failure” on page 52, “10.6 Function of the emergency release” on page 52 or section “Emergency release by Bowden cable” on page 24.

3.4 Product designation

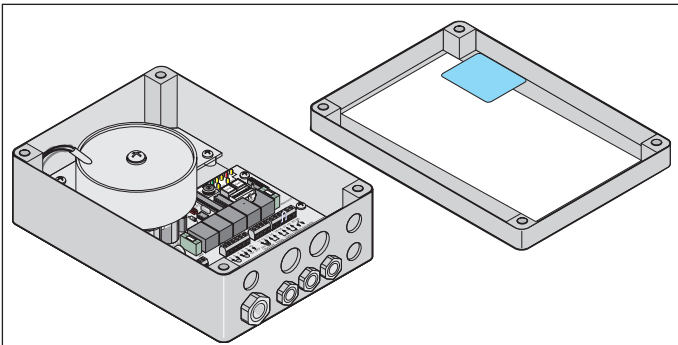

Fig. Control unit with type plate on the inside of the cover

The type plate includes:

- type designation
- Item Number
- date of manufacture with month and year
- serial number

In case of questions or service, please supply the type designation, the date of manufacture and the serial number.

3.5 Explanation of terms used

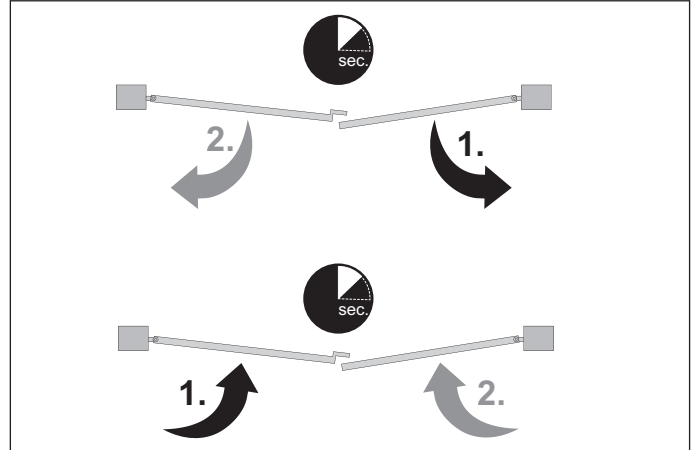

Fig. Example of movement sequence

Left gate/right gate

In this Installation and Operating Manual, it is always assumed that the gate is viewed from the interior of the property. The operators are situated between the two posts and inside the property. The gate opens into the property.

NOTE

When using the operators, note that “Opening gate outwards” represents a deviation from the standard function.

This also results in different conditions for installation, function, operation etc.

Active leaf

Designates the gate leaf which opens first and closes second. The sequence of movements is necessary, e.g. with a locating face on a gate leaf. 1-leaf gates only have an active leaf.

Inactive leaf

Designates the gate leaf which opens second and closes first.

Combined operation

Mixed operation 1x twist M or ML and 1x twist XL or twist 350 only possible in connection with DTA-1 control unit and the “twist XS” conversion set (Item Number: 3248V000).

3. Description of function and product

3.6 Scope of delivery

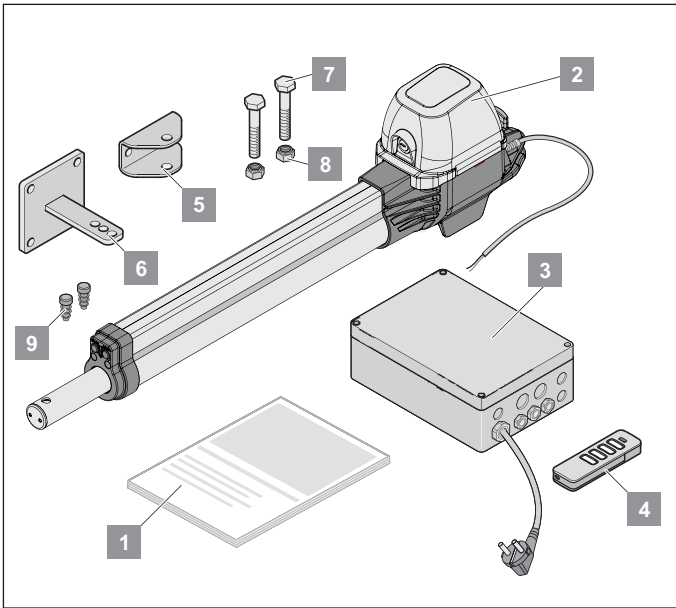

Complete set		1-leaf	2-leaf
twist M weight		8.9 kg	13.9 kg
twist M packaging (L x W x H)		788 x 193 x 205 mm	
twist ML weight		9.7 kg	15.0 kg
twist ML packaging (L x W x H)		990 x 193 x 205 mm	
1	Translation of the Installation and Operating Manual	1x	1x
2	Operator with cable	1x	2x
3	Control unit in housing (including radio receiver, transformer, and mains plug)	1x	1x
4	Hand-held remote control, including battery	1x	1x
5	Fitting for gate leaf	1x	2x
6	Fitting for post or pillar	1x	2x
7	Hex bolt (M10 x 55 mm)	2x	4x
8	Locknut (M10)	2x	4x
9	Lamellar plug	2x	4x

When unpacking, make sure that all parts are included in the packages. The actual scope of delivery may vary depending on the specific operator type.

NOTE

- Mounting material such as screws and dowels are not included. Select suitable mounting material for the respective substructure.

3.7 Technical data

Permitted gate leaf dimensions

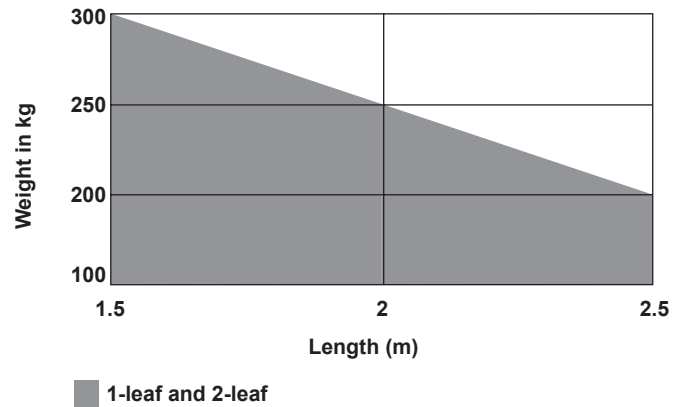

Infill

Height (m)	Infill (%)		
	1.5	2	2.5
2	70	60	50
1.5	90	80	70
1	100	100	100
0.5	100	100	100
Length (m)	1.5	2	2.5

Tab. Ratio: door surface to filling level

Valid for B dimensions 260 mm and A dimensions 80 mm; recorded values for gate leaf thickness 50 mm and centre rotation point, based on the maximum given gate weight.

With inclined gates

⚠ WARNING



Risk of injury in unlocked state!

Risk of injury from uncontrolled shutting in unlocked state with inclined gates which are not weight-balanced.

- ▶ Only use weight-balanced inclined gates.
- ▶ Keep persons and animals clear of the range of movement of the gate.
- ▶ Never put your hand near the gate or near moving parts when the gate is moving.
- ▶ Do not drive through the gate until it has opened completely.

NOTE

- Weight: max. 120 kg
- Length: min. 0.825 m (twist M)
min. 1.0 m (twist ML)
max. 2.5 m
- Gate inclination: max. 10 %

3. Description of function and product



INFORMATION

- Gate fitting: (Item Number: S10758-00001, left gate leaf)
- Door bracket: (Item Number: S10759-00001, right gate leaf)

	twist M	twist ML
Rated voltage	AC 220–240 V	
Rated frequency	50–60 Hz	
Memory positions in radio receiver	40/450 ⁽¹⁾	
Duty cycle	S3 = 15%	
Operating temperature	↕ -25 °C to ↕ +65 °C	
Emission value according to operating environment	47 dB(A)	
IP code control unit	IP65	
IP code operator	IP44	
Protection class	I	
Max. feed speed	16.5 mm/s	
Max. pull and pushing force (per leaf)	2,000 N	
Rated, pull and pushing force (per leaf)	660 N	
Max. power consumption (per leaf)	140 W	
Max. current consumption (per leaf)	0.8 A	
Rated power consumption (per leaf)	75 W	
Rated current consumption (per leaf)	0.5 A	
Power consumption in power-saving mode	2.9 W	
Max. gate weight (per leaf)*	300 kg	
Max. leaf length (per leaf)	0.825 m	1.0 m
Max. leaf length** (per leaf)	2.5 m	
Gate inclination***	10 %	

* With max. 1.5 m gate leaf width, 1-leaf system.

** At max. 200 kg.

*** See section "With inclined gates" on page 13.

⁽¹⁾ 40 SOMloq2 (Memo 450)

3.8 Dimensions, twist M (dimensions in mm)

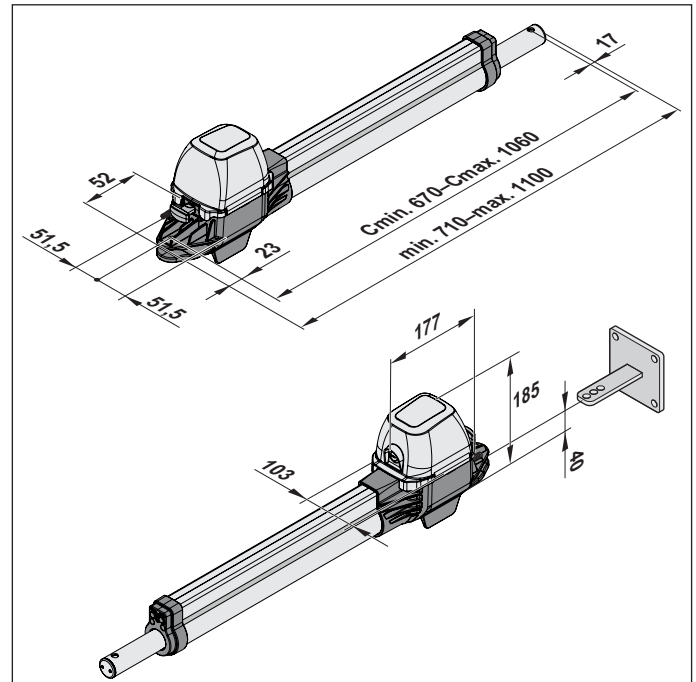

3.9 Dimensions, twist ML (dimensions in mm)

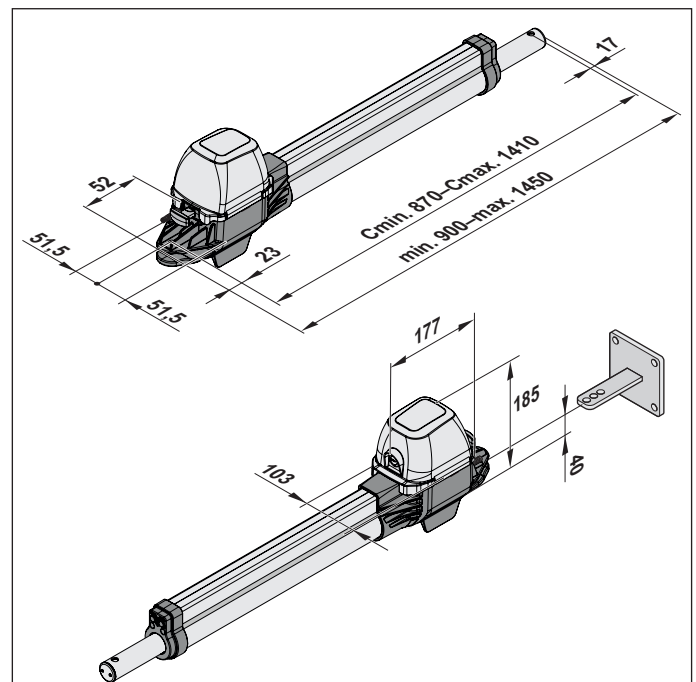

3. Description of function and product

3.10 Connection options

Only **SOMMER** accessories may be used.
Observe the corresponding instructions.

Accessories may only be installed and adjusted
by **qualified specialists**. The use of accessories
can vary depending on the type.

Control unit	twist M	twist ML
2-wire photocell	–	–
4-wire photocell	•	•
Electric lock DC 24 V	•	•
Connecting cable set 7 m (IP67)	•	•
Button 1	•	•
Button 2	•	•
Warning light DC 24 V, 25 W	•	•
SOMup4 S2	•	•
Memo	•	•
Output DC 24 V	•	•
Key switch	•	•
Terminal for accumulator	•	•
DIP switch	8	8

4. Installation

4.1 Required tools and personal protective equipment

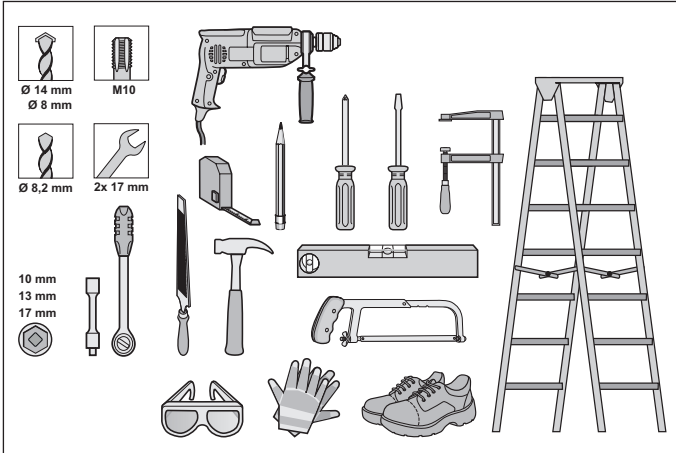

Fig. Recommended tools and personal protective equipment for installation

Tools	Size
Phillips screwdriver	PH2
Flat head screwdriver	3.5 mm
Socket wrench	SW4
Allen wrench	8 mm
Fork or ring wrench	17 mm
Ratchet	
Ratchet insert	10/13/17 mm

We recommend the use of the tools and protective equipment shown above to assemble and install the operator. Lay out the required tools and personal protective equipment beforehand to ensure fast and safe installation.

Wear your personal protective equipment. This includes safety glasses, safety gloves and a safety helmet.

4.2 Important notes and information

In particular, please observe and comply with the following warnings, notes and information to ensure safe installation.

DANGER



Danger if not observed!

If warnings are not observed, serious injury or death may result.

- ▶ In particular, observe the warnings below.
- ▶ In addition, observe the safety instructions in Chapter “2. General safety instructions” from page 9.

WARNING



Danger of tripping and falling!

Unsafely positioned parts such as packaging, operator parts or tools may cause trips or falls.

- ▶ Keep the disassembly area free of unnecessary items.
- ▶ Place all parts where no-one is likely to trip or fall over them.
- ▶ The general workplace guidelines must be observed.



Risk of injury to body!

During welding, the body and in particular eyes and hands may be seriously injured by radiation or sparks as well as mechanical and thermal hazards.



When welding, wear appropriate personal protective equipment such as:



- ▶ face protection
- ▶ protective clothing
- ▶ safety gloves



Danger due to optical radiation!

Looking into an LED at short range for an extended period may cause optical glare. This may temporarily reduce vision. This may cause serious or fatal accidents.

- ▶ Never look directly into an LED.



Risk of eye injury!

Chips flying when drilling may cause serious injuries to eyes and hands.

- ▶ Wear safety glasses when drilling.



Risk of injury to feet!

Falling parts can cause serious foot injuries.

- ▶ Safety shoes must be worn when performing work on the gate.



CAUTION



Risk of injury in the head region!

Impact with suspended objects may cause serious abrasions and cuts.

- ▶ You must wear your personal safety helmet when disassembling suspended parts.



Danger of abrasions and cuts!

Rough metal parts may cause abrasions and cuts when picked up or touched.

- ▶ You must wear your personal safety gloves when working with rough metal parts.



4. Installation

→ NOTE

- If the gates or the gate posts are unstable, parts could break and fall off.
Objects may be damaged. Gates and gate posts must be stable.
- To prevent damage to the gate or operator, use only suitable and, where applicable, mounting material approved for public areas. The mounting material must be suitable for the material of the gates and gate posts.
- Damage to the gate system can occur if the gate leaves are relatively large or the leaf filling level is high and there is high wind pressure. We recommend using electric locks for secure locking.

4.3 Preparing for installation

Requirements for installation

Before installation, you **must** check whether the operator is suitable for the gate. For information on the permissible weights of the gate leaves, see Chapter “**3.7 Technical data**” on page 13.

In the case of 1-leaf and 2-leaf gates, an end stop **must** be installed on the gate side at the gate CLOSE and gate OPEN end positions.

→ NOTE

- We recommend installing the control unit on the property to protect the control unit against possible damage by third parties.

Removal of actuation parts and unsuitable components

Before installation, remove:

- manual locking on gate
- all cords or straps necessary to operate the gate by hand
- all manual locking systems, e.g. locks or bolts

→ NOTE

- If attached parts, e.g. bolts or locks, are installed on a gate, they may block the operator. This may cause faults or damage to the operator.
Before installing the operator, remove all unsuitable attached parts or reliably disable them.

Check the existing gate mechanism and installation posts

Before beginning installation, you **must** ensure that the operator is suitable for the existing gate system.

The existing gate system **must** meet the following criteria:

- Length of one leaf (min. 825 mm twist M/1,000 mm twist ML) to max. 2,500 mm, see Chapter “**3.7 Technical data**” on page 13
- Max. gate height 2,000 mm
- Maximum weight of an individual gate leaf 300 kg, see Chapter “**3.7 Technical data**” on page 13
- Weight should be evenly distributed
- It **must** be possible to move the gate leaf easily by hand over the entire swivel range
- The gate leaf **must** stand still in every position and must not move independently into a default state
- Stable installation posts.

Check all existing accessories for proper function and exchange them if necessary. Only original accessories from **SOMMER** may be connected.

4. Installation

4.4 A/B dimension tables (reference values)

NOTE

Before mounting, define the A/B dimensions. Without the A/B dimensions, the operator cannot be correctly installed and operated.

- Observe the different post and pillar dimensions.

i INFORMATION

- **White fields:** Installation range only for horizontal gates.
- **Grey fields:** Installation range for inclined and horizontal gates.
- **Attention:** Only use inclined gates with special gate fittings:
- **Gate fitting:** (Item Number: S10758-00001, left gate leaf)
- **Gate fitting:** (Item Number: S10759-00001, right gate leaf)

NOTE

Select the A/B dimensions so that the desired opening angle (D) is reached. The specified opening angle is a reference value for the largest possible angle.

- For gate leaf lengths of greater than 1.5 m or full surface closed gates, the B dimension must be at least 140 mm.
- As the data in the dimension tables may vary depending on the gate mechanism, they should be checked in advance.

NOTE

The reference values in the dimension tables have been calculated based on the following data:

- Wind speed 28.3 m/s
- Gate height 2.0 m
- Gate width 2.5 m
- Gate filling 35 %, uniformly distributed
- Without electric lock

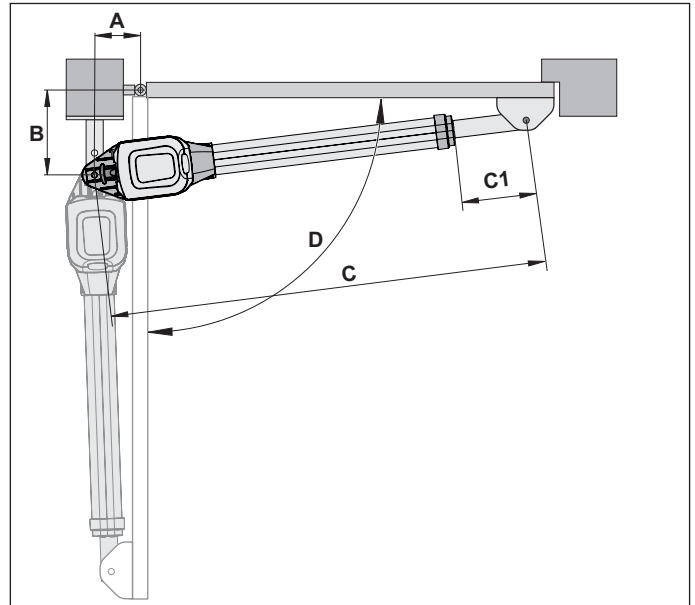

Fig. Dimensioning – values in accordance with dimension tables

Dimension table twist M

B	A		80	100	120	140	160	180	200	220	240	260	Max. gate leaf width without electric lock								
	C	C1																			
		D																			
100	851	221	875	245	918	288	957	327	994	363	1026	369	1041	411	1043	413	1051	421	1040	410	1.5 m
		90°		93°		105°		113°		118°		120°		115°		108°		100°		98°	
120	872	242	896	266	935	305	968	338	1001	374	1035	405	1041	411	1042	412	1040	410	1037	407	
		90°		93°		103°		108°		113°		115°		108°		102°		97°		93°	
140	894	242	918	288	951	321	987	357	1018	388	1048	418	1040	410	1040	410	1038	408	1043	407	2.5 m
		90°		93°		100°		107°		110°		112°		101°		96°		92°		90°	
160	916	286	940	310	971	341	1001	371	1035	405	1049	419	1051	421	1040	410					
		90°		93°		99°		103°		108°		104°		98°		91°					
180	938	308	961	332	991	361	1021	391	1050	420	1041	410	1050	420							
		90°		93°		98°		102°		105°		94°		92°							
200	961	331	984	354	1010	380	1039	409	1042	412											
		90°		93°		96°		100°		93°											
220	983	354	1008	378	1032	403	1051	421													
		90°		93°		96°		95°													
240	1007	399	1031	401																	
		90°		93°																	
260	1030	400																			
		90°																			

4. Installation

Dimension table twist ML

B	A			80	100	120	140	160	180	200	220	240	260	280	Max. gate leaf width without electric lock	
	C	C1	D													
100				1041 216 90°	1065 240 93°	1108 283 105°	1147 322 113°	1183 358 118°	1216 391 120°	1256 431 125°	1298 473 130°	1317 592 125°	1346 521 125°	1376 551 125°		1.5 m
120				1062 237 90°	1086 261 93°	1128 303 103°	1158 333 108°	1194 369 113°	1235 410 115°	1264 439 120°	1304 479 125°	1321 596 120°	1349 524 120°	1376 551 120°		
140				1083 258 90°	1107 282 93°	1141 316 100°	1177 352 107°	1208 383 110°	1244 419 115°	1279 354 118°	1309 484 125°	1340 515 120°	1358 533 117°	1377 552 115°		
160				1105 280 90°	1129 304 93°	1160 335 99°	1191 366 103°	1245 400 108°	1258 433 112°	1292 567 115°	1316 491 122°	1360 536 120°	1372 547 115°	1385 560 112°		
180				1127 302 90°	1151 326 93°	1180 355 98°	1210 385 102°	1246 421 108°	1279 454 112°	1308 583 113°	1331 506 120°	1372 547 117°	1392 567 115°	1398 573 110°		
200				1149 324 90°	1173 348 93°	1199 374 96°	1230 405 101°	1261 436 105°	1296 471 110°	1326 501 112°	1364 539 117°	1387 562 115°	1396 571 110°	1398 573 105°		2.5 m
220				1171 346 90°	1195 370 93°	1221 396 96°	1252 427 101°	1283 458 105°	1316 491 109°	1343 518 110°	1380 555 115°	1393 568 110°	1398 573 105°	1396 571 100°		
240				1194 369 90°	1218 393 93°	1242 417 95°	1273 448 100°	1305 480 105°	1335 510 108°	1364 540 110°	1397 572 113°	1399 574 105°	1399 574 100°	1392 567 95°		
260				1217 392 90°	1241 416 93°	1265 440 95°	1295 470 100°	1324 499 103°	1353 390 106°	1380 555 107°	1398 573 105°	1380 555 95°	1398 573 95°	1386 561 90°		
280				1240 450 90°	1264 439 93°	1289 463 95°	1316 491 99°	1344 519 102°	1374 519 105°	1389 573 105°	1405 579 100°	1389 564 92°	1394 569 90°			
300				1264 439 90°	1287 462 93°	1311 486 95°	1337 512 98°	1365 540 101°	1392 567 103°	1390 565 95°	1408 583 95°					
320				1287 462 90°	1311 486 93°	1334 509 95°	1371 536 98°	1388 563 101°	1394 569 95°	1401 576 92°						
340				1311 486 90°	1334 509 93°	1358 532 95°	1382 557 97°	1410 585 100°								
360				1353 510 90°	1358 533 93°	1382 557 95°										
380				1359 534 90°	1382 557 93°											
400				1380 558 90°												

4.5 Fittings

⚠ CAUTION



Only use permissible fastening materials!

Fasten fittings on stone or cement pillars with expansion dowels or adhesive-bonded anchors.

- ▶ The fastenings must not loosen during operation.



INFORMATION

- Flying sparks can damage the operator, e.g. when welding on posts or gate leaves.
- Cover or disassemble operator before welding.
- Welding and grinding residues accelerate corrosion of the fittings.
- After mounting the fittings, do not perform any more welding or grinding work.

➔ NOTE

- The strength of the included fittings is designed for the operator. The warranty expires if other fittings are used.
- The B dimensions **must** be at least 100 mm (see “A/B dimension table”). Compensation for smaller B dimensions with a space plate under the post fitting.
Maintain clearances between the gate leaf and post or gate leaf and operator in accordance with the applicable standards.

Steel posts

- Note the thickness of the post.
- Weld or bolt the fitting directly to steel posts.

Brick or concrete pillars

- Maintain the distance between the fastening holes and the pillar edge. The distance depends on the type of expansion dowels or adhesive-bonded anchors. Observe the recommendations of the manufacturer.

4. Installation

Post/pillar fitting (dimensions in mm)

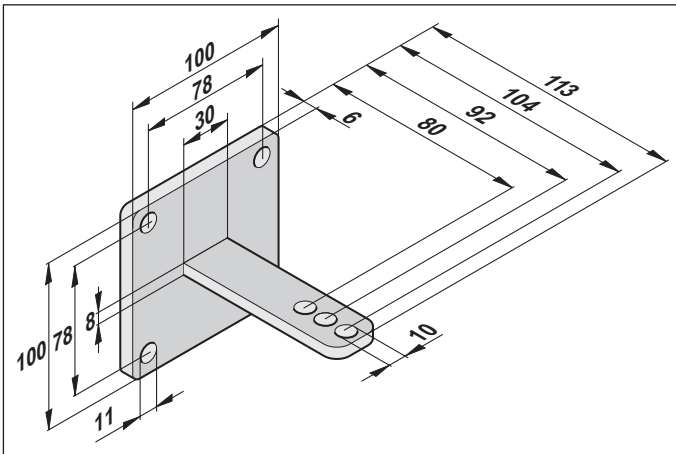

Gate leaf fitting (dimensions in mm)

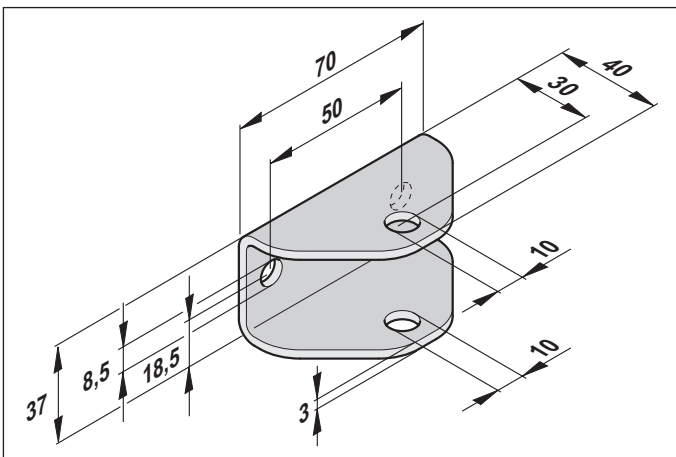

Timber post fittings (dimensions in mm)

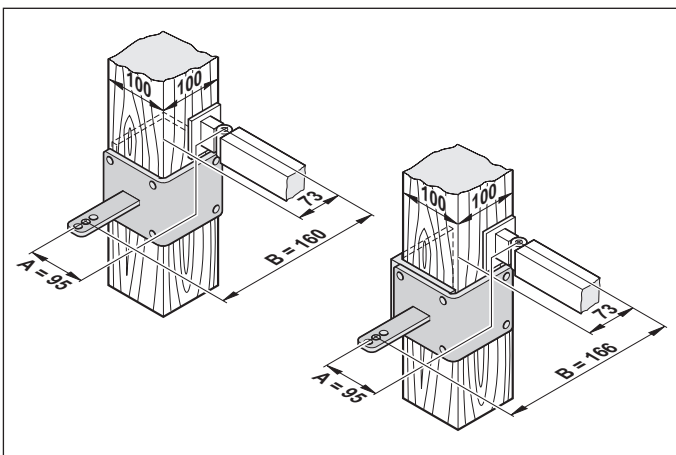

Special fittings for internal rotation points

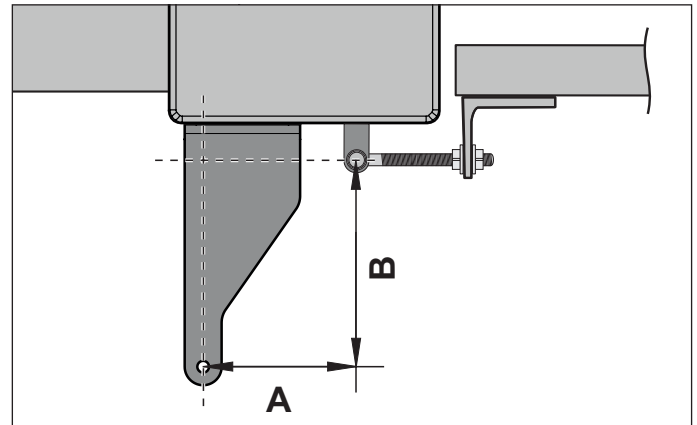

Fig. Internal rotation point

i INFORMATION

- In order to comply with the required A/B dimensions in the case of internal rotation points, it may be necessary to use special fittings in order to ensure professional installation.
- For internal rotation points, the rotation point of the operator must be towards the gate hinge.

NOTE

- Before beginning installation of the operator, make sure that the gate post fittings (special fittings) are suitable for professional installation.
- Carry out installation in accordance with the specifications in the respective A/B dimension table.

Further information on gate post fittings:



<https://b2b.de.sommer.eu/zubehoer/drehtorantriebe/beschlaege-drehtorantriebe.html?>

4. Installation

Deviation of post fittings

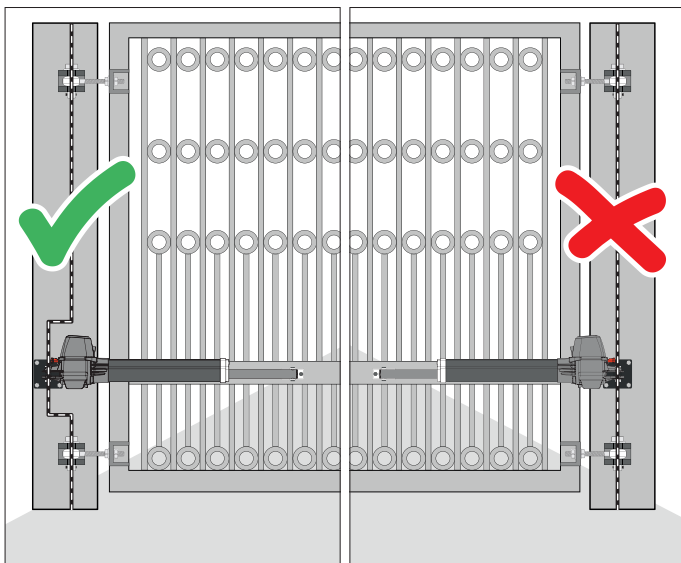

Fig. 1 Rotation point correct Fig. 2 Rotation point incorrect

1. Rotation point of the operator installed offset to gate hinge (in acc. with specifications A/B dimension table).
2. Rotation point of the operator and gate hinge are installed parallel in one line (**A dimension = 0**). Gate can no longer be opened to 90°!

4.6 Installing the operator

1. Close the gate by hand.
2. Compare the A and B dimensions with the A/B dimension table.
3. Fasten the post/pillar fitting temporarily (e.g. with a clamp).
4. Check installation situation and dimensions.
 - ⇒ Observe required distance to the floor: at least 50 mm.
5. Fasten post/pillar fitting.

twist M (dimensions in mm)

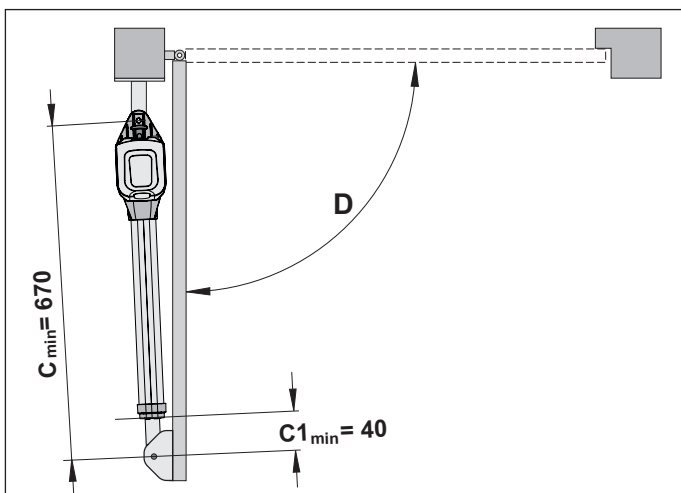

twist ML (dimensions in mm)

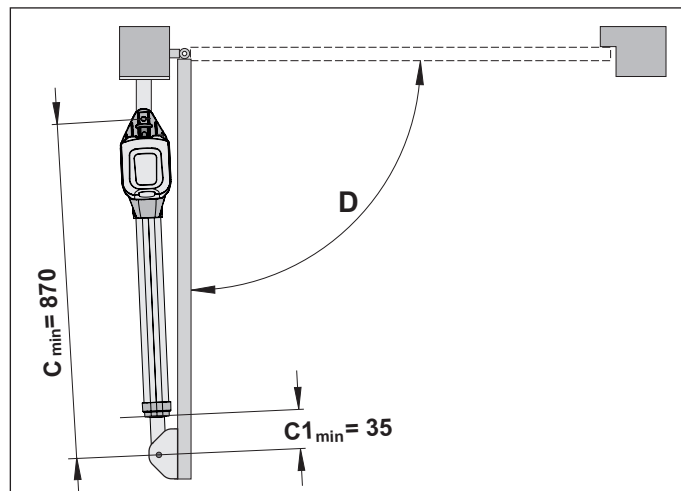

6. Move the gate by hand to the “Gate OPEN” position. Note the maximum possible opening angle (**D**) from the A/B dimension table.
7. Hang the operator in the post fitting and secure it with a screw.
 - ⇒ The operator thrust tube is at maximum retraction as delivered.
8. Unscrew thrust tube, at least to $C1_{min}$.
9. Fix the gate leaf fitting to the thrust tube.
10. Insert the screw from above.
11. Fasten the gate leaf fitting temporarily to the gate (e.g. with a clamp).
12. Unlock operator, see Chapter “4.10 Locking and unlocking the operator” on page 23.
13. Close the gate by hand.

twist M (dimensions in mm)

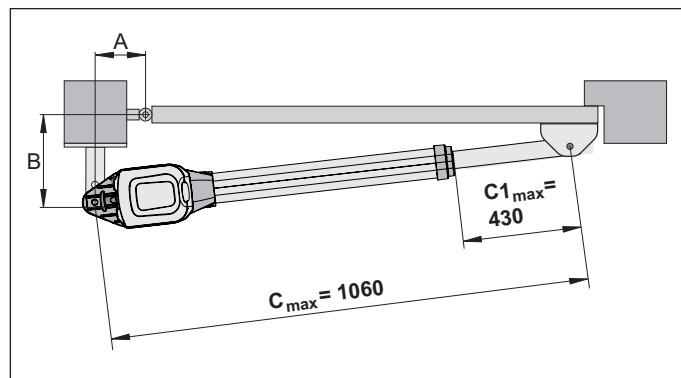

4. Installation

twist ML (dimensions in mm)

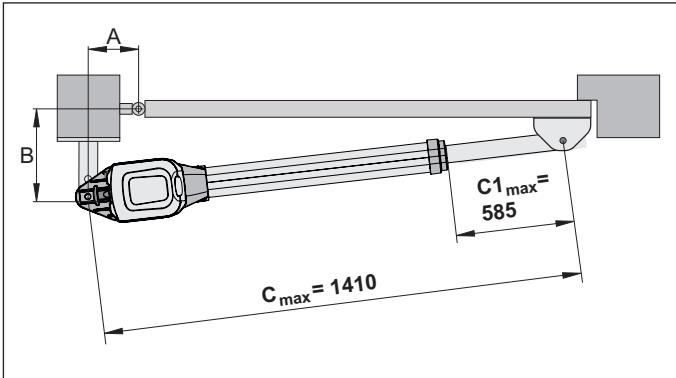

NOTE

- The smaller the C1 dimension, the higher the stability.

14. Measure C1 dimensions and set between $C1_{min}$ and $C1_{max}$. Do not exceed $C1_{max}$.
15. Check that the operator is horizontal in the positions:
 - "Gate OPEN"
 - "Gate CLOSE"
 - opened 45°
16. Check the position of the gate leaf fitting.
17. Fix gate leaf fitting.
18. Screw in the nuts of the connecting screws (operator to fitting) only tight enough that the gate with the operator can still be turned easily.

Observe spare cable

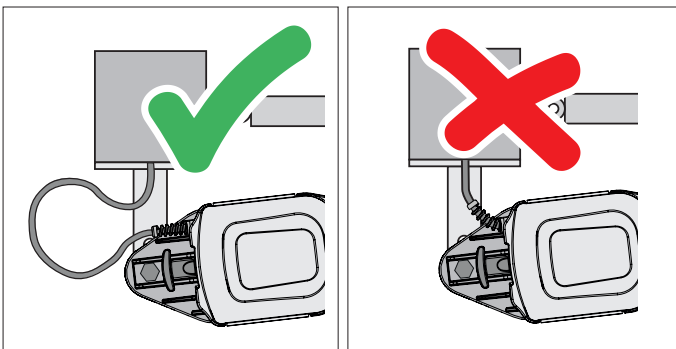

Fig. 2 correct

Fig. 2 incorrect

1. Allow for a corresponding spare cable length (cable connection) depending on the installation situation and gate opening (inwards/outwards).

NOTE

- The cable radius **must** be large enough to prevent tension on the cable.
- Cable breakage may result if the radius is too small.

4.7 Opening/closing the control unit housing

NOTE

Before opening the control unit housing, make sure that no moisture can penetrate the housing after removal of the housing cover.

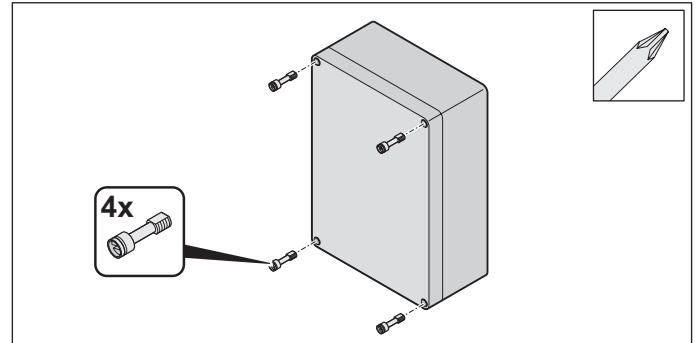

1. Release the screws of the housing cover.
 - ⇒ Remove the housing cover.
2. Put housing cover in position and insert screws.
 - ⇒ Tighten screws again to prevent ingress of moisture into the control unit housing.

4.8 Installing the control unit

CAUTION



Danger of destruction by moisture

Penetration of moisture may destroy the control unit.

- ▶ Only screw the housing on at the intended fixing points.
- ▶ Install the housing vertically with the cable conduits facing downwards.
- ▶ Permitted cross-section of cable conduits: 1.5 mm^2 to 2.5 mm^2 .
If cable cross-sections are smaller, insert bushing adapters into the cable conduits.
- ▶ Fit the cover so that it sits flush.

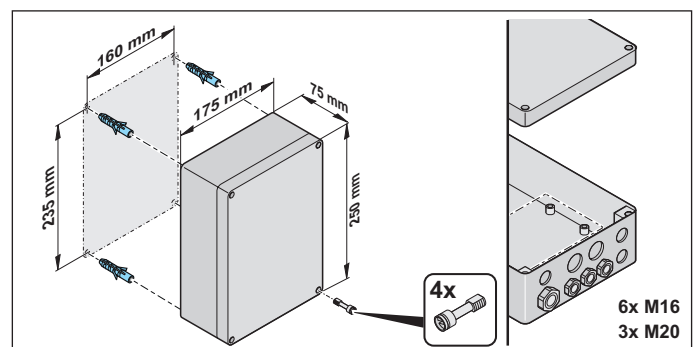

Fig. Installation example for mounting of the control unit
The scope of delivery does not include mounting material.

4. Installation

NOTE

- To prevent damage to the gate or operator, use only suitable and, where applicable, mounting material approved for public areas. Select suitable mounting material for the respective substructure.
- Always install the control unit housing upright with the cable inlets facing downwards. Use only the fixing points provided. The control unit is then protected in accordance with IP65.
- Powerful sprays of water lead to damage to the control unit. Protect the control unit housing against powerful jets of water, e.g. from a garden hose.
- To prevent damage to the operator, do not connect the control unit to the power supply until installation is complete.

1. Mark holes at the desired positions and drill. Attach the control unit with suitable material.

✓ **The control unit is attached.**

4.9 Removing/fitting the cover

Removing the cover

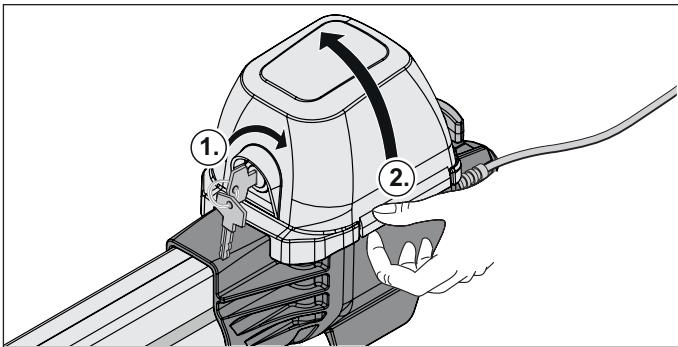

1. Insert key (1) and turn 35° to the right.
2. Remove the cover (2).

Fitting the cover

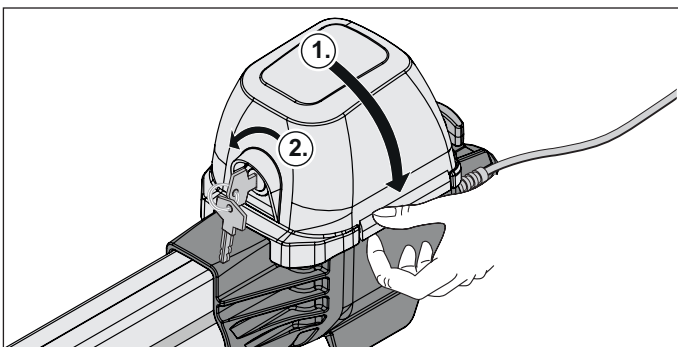

1. Put the cover (1) in position.
2. Insert key (2) and turn it 35° to the left.

4.10 Locking and unlocking the operator

Unlocking the operator

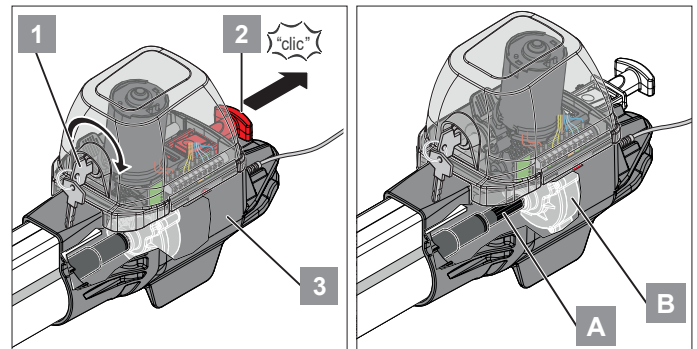

Fig. 1

Fig. 2

1. Insert key (1) and turn 35° to the right.
2. Pull the emergency release lever (2) away from the housing (3) until it locks into place.
To simplify unlocking: Move gate leaf manually.
⇒ The operator is unlocked.
⇒ The gate can now be moved by hand.
3. The threaded spindle (A) is disconnected from the motor (B)!

Locking the operator

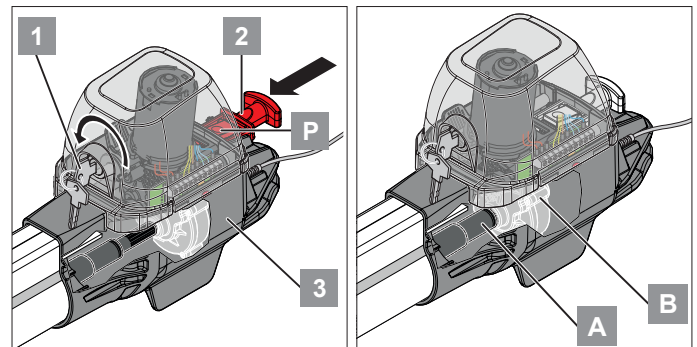

Fig. 1

Fig. 2

1. Press button (P) down and hold.
2. Move emergency release lever (2) towards housing (3).
3. Insert key (1) and turn it 35° to the left.
⇒ Operator is locked.
⇒ The gate can now only be moved using the operator.
4. The threaded spindle (A) is coupled to the motor (B)!

4. Installation

Emergency release by Bowden cable

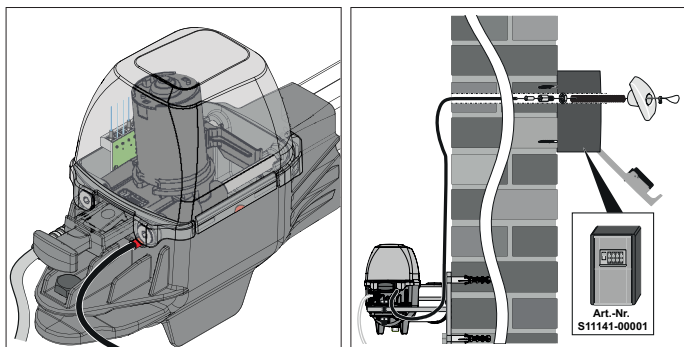

Fig. 1

Fig. 2

1. Bowden cable mounted on the operator (unlocked state).
2. Installation example with key safe.

NOTE

- You can download the instructions for installing the Bowden cable for unlocking from our web site.
<https://downloads.sommer.eu/?category=43>

4.11 Connecting operators to the control unit

Gate opening inwards (1-/2-leaf)

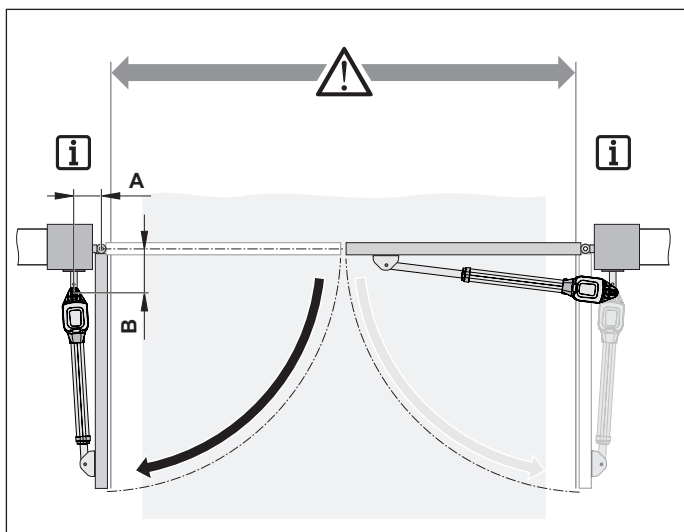

Fig. Gate system opening inwards

1-leaf gate (gate opening inwards)

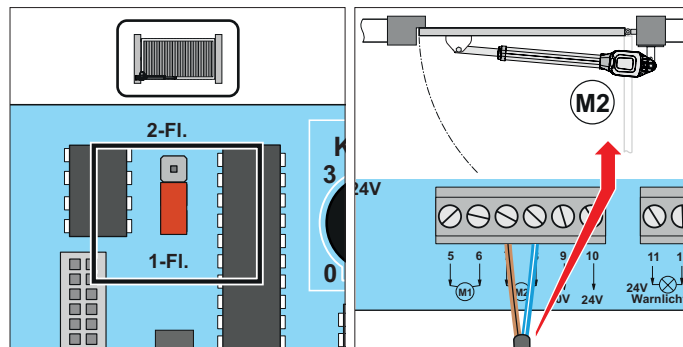

Fig. 1-leaf

Fig. M2

Terminal	Designation	Description
7	M2	Motor cable (brown)
8	M2	Motor cable (blue)

1. Plug-in position of the jumper for 1-leaf gates.
2. Connection of the motor for 1-leaf gates.

2-leaf gate (gate opening inwards)

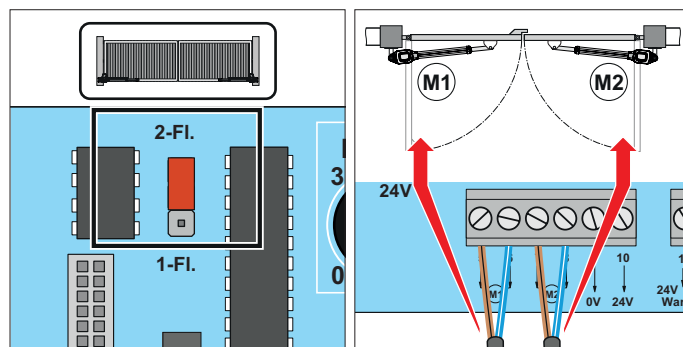

Fig. 2-leaf

Fig. M1 + M2

Terminal	Designation	Description
5	M1	Motor cable (brown)
6	M1	Motor cable (blue)
7	M2	Motor cable (brown)
8	M2	Motor cable (blue)

1. Plug-in position of the jumper for 2-leaf gates.
2. Connection of the motor for 2-leaf gates.

4. Installation

Gate opening outwards (1-/2-leaf)

NOTE

- The gate post fittings in the diagram below are examples of fittings.
- These fittings must be manufactured individually by a door builder or metalworker, depending on the size of the gate and the posts.

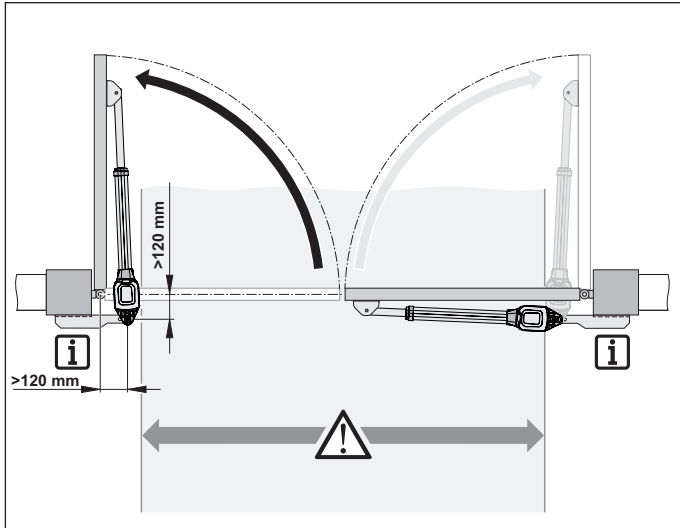

Fig. Gate system opening outwards

1-leaf gate (gate opening outwards)

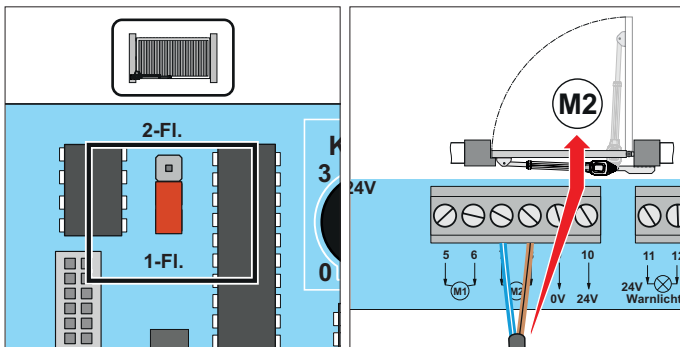

Fig. 1-leaf

Fig. M2

Terminal	Designation	Description
7	M2	Motor cable (blue)
8	M2	Motor cable (brown)

1. Plug-in position of the jumper for 1-leaf gates.
2. Connection of the motor for 1-leaf gates.

2-leaf gate (gate opening outwards)

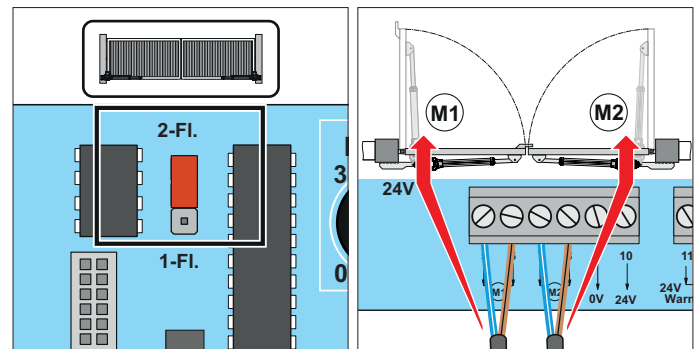

Fig. 2-leaf

Fig. M1+M2

Terminal	Designation	Description
5	M1	Motor cable (blue)
6	M1	Motor cable (brown)
7	M2	Motor cable (blue)
8	M2	Motor cable (brown)

1. Plug-in position of the jumper for 2-leaf gates.
2. Connection of the motor for 2-leaf gates.

5. Electrical connection

5.1 Mains connection

The power cord supplied may only be used for initial operation. After initial operation, it **must** be replaced with a suitable fixed mains connection.

The power outlet for the power cord **must** be protected by a fuse.

The mains power cannot be connected until all other connections have been established. The connection to an accumulator is established last.

Electrical connection must be performed by a **trained electrician**. Local and national installation regulations (e.g. VDE) must be observed.

In particular, observe the warnings below.

DANGER



Danger due to electric current!

Contact with live parts may result in electric current flowing through the body. Electric shock, burns or death will result.

- ▶ The control unit must be connected to the power mains by a **trained electrician!** Only use this power cord for installing and commissioning the operators. After completing installation and commissioning, the mains cable must be disconnected and replaced by a permanently laid line.
- ▶ The mains cable supplied is not approved for constant or outdoor operation. The mains connection must be in accordance with EN 12453 (omnipolar mains circuit breaker). Before doing any work on the gate or operator, disconnect it from the power supply and lock it to prevent reconnection.
- ▶ All disassembly work on electrical components must be carried out by a **trained electrician**.
- ▶ Disconnect the mains plug before disassembling the operator.
- ▶ If an accumulator is connected, disconnect it from the control unit.
- ▶ Check that the operator is not live.
- ▶ Secure the operator against being switched back on.

INFORMATION

- All devices to be connected externally **must** have safe isolation of the contacts from the mains voltage supply in accordance with IEC 60364-4-41. Wiring for external devices must be installed in accordance with IEC 60364-4-41. All electrical wiring must be firmly secured to prevent displacement.

NOTE

In order to maintain the functionality of the technical equipment, we recommend that you observe the specified maximum lengths and minimum cross-sections for power cables!

Connection lines	Signal lines
Maximum length 20 m	Maximum length 25 m
Minimum cross-section 1.5 mm ²	

Approved wire cross sections for all terminals: 1 mm² to 2.5 mm².

Do not remove the sheath of the supply line until it is in the housing!

- Insert the sheath of the connecting line into the control unit housing.
- Remove the line sheaths as shown in the graphic.

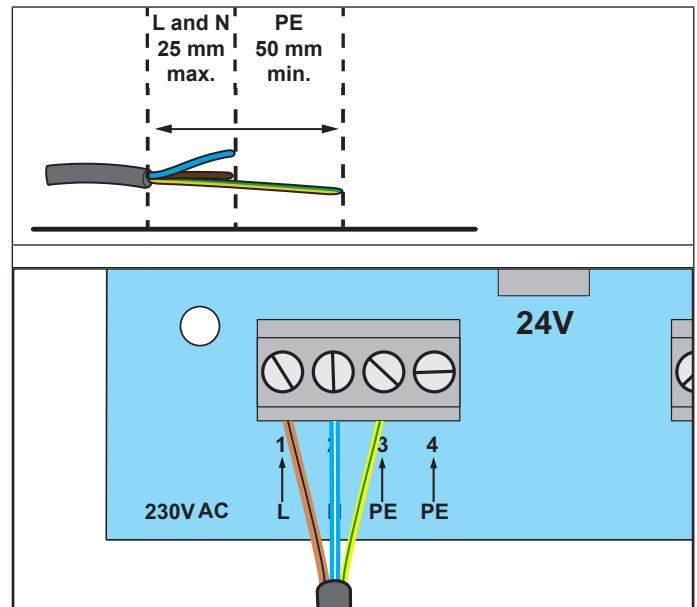

Terminal	Designation	Description
1	L	Outer conductor AC 230 V
2	N	Neutral wire
3 + 4	PE	Protective earthing conductor

5. Electrical connection

Connecting the main switch

Connection must be carried out by a **trained electrician!**

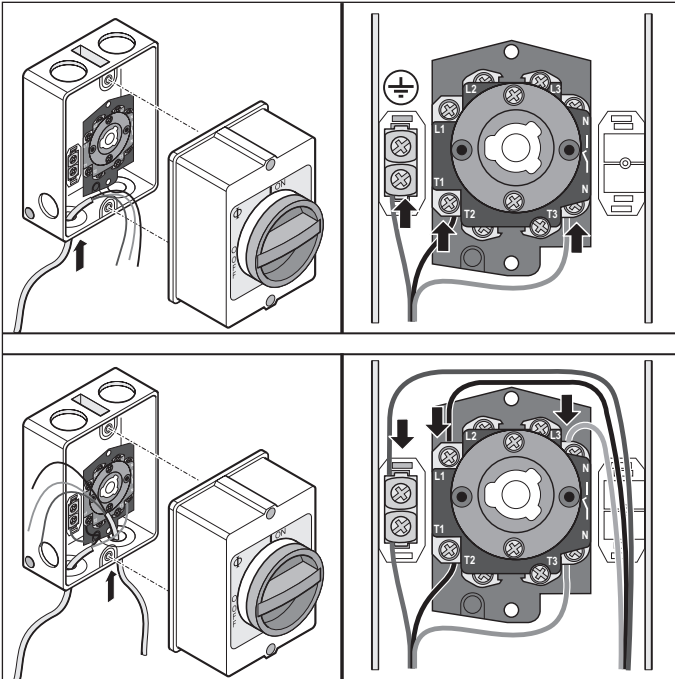

→ **NOTE**

- For installation, follow the instructions in the separate installation and operating manual from the respective manufacturer.
- In the connection diagram for the control unit, you will also find the assignment of the connections for the main switch, see “**Connection diagram**” on page 67.

5. Electrical connection

5.2 Circuit board of the control unit

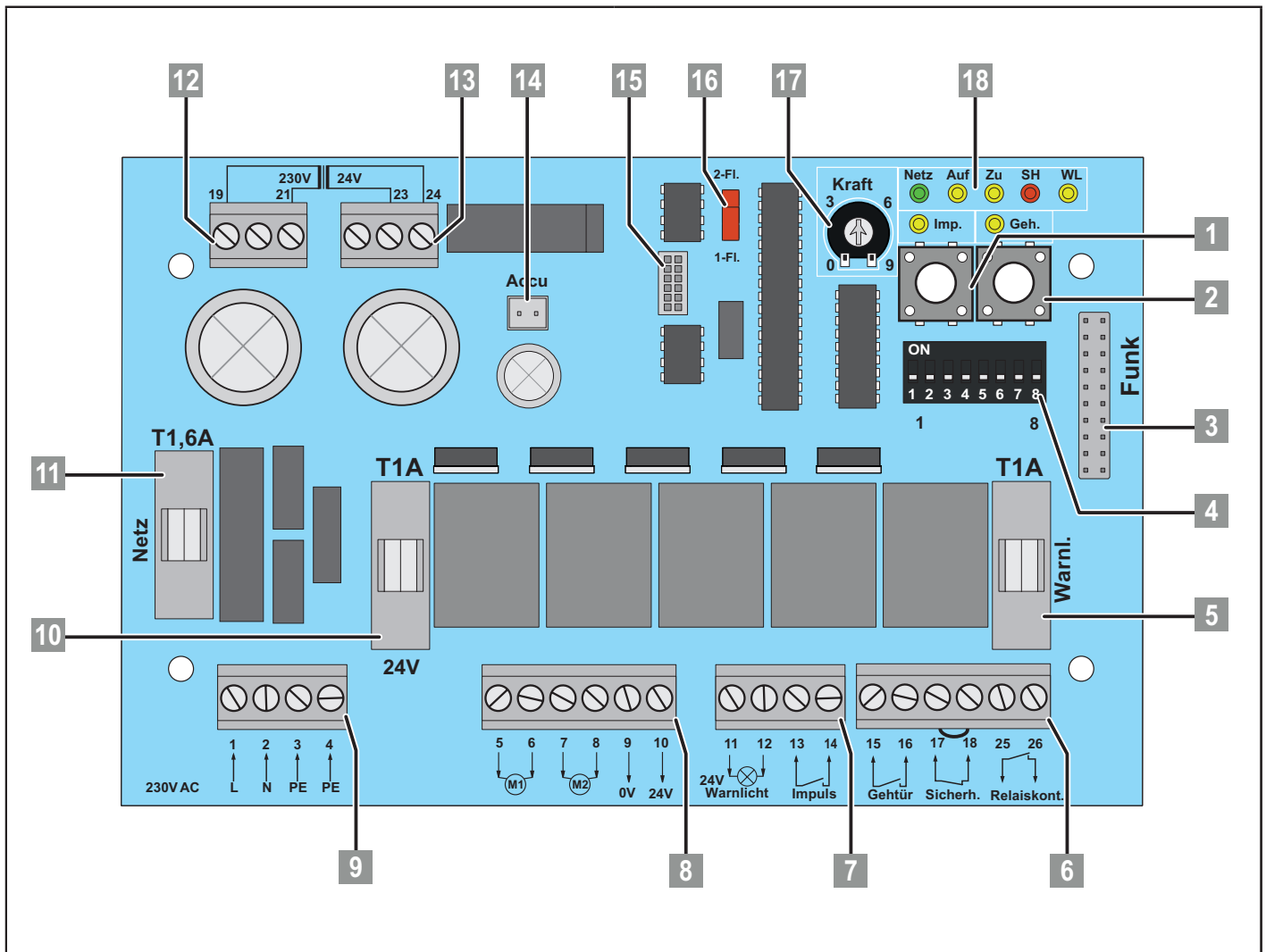

1 Button (Imp. red)

Pulse button

OPEN – STOP – CLOSE

2 Button (Geh. red)

Pulse button – walk-through gate/1-leaf operation

OPEN – STOP – CLOSE

3 Radio slot

Terminal for radio module (SOMup4)

Mounted at the factory

4 DIP switch (1–8)

Selection switches for operating modes/special functions

See Chapter “15. Connection diagrams and functions of the DIP switches” on page 66.



Prewired

5 Fuse

Warning light output DC 24 V, Terminal 11–12

(1 A, slow-blow)

5. Electrical connection

6 6-pin terminal block (black)

MUFU connection

Floating relay contact, Terminal 25–26



Relay is activated – for 3 seconds when motor is started



Time can be set via TorMinal

Safety input connection

Floating normally closed contact, Terminal 17–18



Wire breaks prewired

Button connection – walk-through gate/1-leaf operation

Floating, Terminal 15–16

OPEN – STOP – CLOSE (leaf 2)

7 4-pin terminal block (black)

Pulse connection

Floating, Terminal 13–14

OPEN – STOP – CLOSE (leaf 1 and 2)

Warning light connection

DC +24 V, max. 25 W (unstabilised DC 22–32 V), Terminal 11–12



Blinks during movement



Continuous light/pre-warning time can be activated (see overview of DIP switches)

8 6-pin terminal block (black)

Output 24 V (external devices)

DC +24 V, max. 30 W (unstabilised DC 22–32 V), Terminal 11–12

- Terminal 9 = GND
- Terminal 10 = DC +24 V

Motor connection 2

1-leaf operation or 2-leaf walk-through gate

Motor 2 (M2) Connect active leaf to control unit and set.

(**Active leaf:** gate leaf which opens first and closes second)

- Terminal 7 = brown (+)
- Terminal 8 = blue (–)

Motor connection 1

2-leaf operation

Motor 1 (M1) Connect inactive leaf to control unit and set.

(**Inactive leaf:** gate leaf which opens second and closes first)

- Terminal 5 = brown (+)
- Terminal 6 = blue (–)



Prewired

9 4-pin terminal block (black)

Mains connection

AC 220–240 V/50–60 Hz

- Terminal 1 = 1 L
- Terminal 2 = N (blue)
- Terminal 3+4 = PE (green/yellow)

Permissible cable cross-section 1.5 mm²–2.5 mm²

10 Fuse

Power supply output DC 24 V, Terminal 9–10

(1 A, slow-blow)

11 Fuse

Mains supply line AC 230 V, Terminal 1–4

(1.6 A, slow-blow)

12 3-pin terminal block

Primary side transformer

AC 220–240 V/50–60 Hz

- Terminal 19
- Terminal 21



Prewired

13 3-pin terminal block

Secondary side transformer

AC 24 V

- Terminal 19
- Terminal 21



Prewired

5. Electrical connection

14 Akku slot, 2-pin

AC 24 V

15 TorMinal slot

Optional accessories for configuration of the control unit by specialist technician.

16 Jumper slot

Configuration for 1- or 2-leaf operation

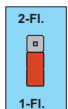

1-leaf operation

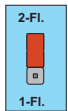

2-leaf operation

17 Potentiometer

Setting the force tolerance



Centre position



- 0 = lowest tolerance (left stop)
- 9 = highest tolerance (right stop)

The potentiometer setting is imported again at every start.

18 Status LEDs

Show the status of the control unit

Mains (green)

- Off = voltage supply interrupted
- On = mains voltage present

Imp. (yellow)

- Off = idle
- On = Imp. button/radio channel 1 actuated

Geh. (yellow)

- Off = idle
- On = Geh. button/radio channel 2 actuated

Open (yellow)

- Off = idle
- On = gate opens

Close (yellow)

- Off = idle
- On = gate closes

SH (red)

- Off = idle
- On = safety input interrupted (e.g. photocell tripped)

WL (yellow)

- Off = idle with programmed force values
- Blinks = test mode
- Blinks = programming run (also at standstill)
- Blinks = during every "Gate OPEN" or "Gate CLOSE" gate movement
- On = gate opens and closes with programmed force values.
- On = warning light on

6+8 Connecting 4-wire photocell

Terminal 9 = GND

Terminal 10 = DC +24 V

Terminal 17 = Signal

Terminal 18 = COM

DC 24 V with max. 1.25 A/30 W
(unstablised DC 22–32 V)

Remove jumper (terminal 17 + 18)



Direction of action gate Close/gate reverses



Direction of action and behaviour can be set
(see overview of DIP switches)

6. Initial operation

6.1 Important notes and information

In particular, observe the warnings below.

DANGER



Danger if not observed!

If warnings are not observed, serious injury or death may result.

- ▶ All warnings must be complied with.
- ▶ In addition, observe the safety instructions in Chapter “2. General safety instructions” from page 9.

WARNING



Danger of crushing and shearing!

If the gate is not visible and the radio control is operated, crushing and shearing injuries to persons may occur.

- ▶ In particular when operating control elements such as the radio control, all danger zones must be visible during the entire gate operation.
- ▶ Always keep the moving gate in sight.
- ▶ Keep persons and animals clear of the range of movement of the gate.
- ▶ Never put your hand near the gate when it is moving or near moving parts.
- ▶ Do not drive through the gate until it has opened completely.
- ▶ Store all handheld transmitters so that unauthorised or accidental operation, e.g. by children or animals, is impossible.
- ▶ Never stand in the opened gate.

6.2 Adjusting the end positions



Danger due to electric current!

Contact with live parts may result in electric current flowing through the body. Electric shock, burns or death will result.

- ▶ All disassembly work on electrical components must be carried out by a **trained electrician**.
- ▶ Disconnect the mains plug before disassembling the operator.
- ▶ If an accumulator is connected, disconnect it from the control unit.
- ▶ Check that the operator is not live.
- ▶ Secure the operator against being switched back on.

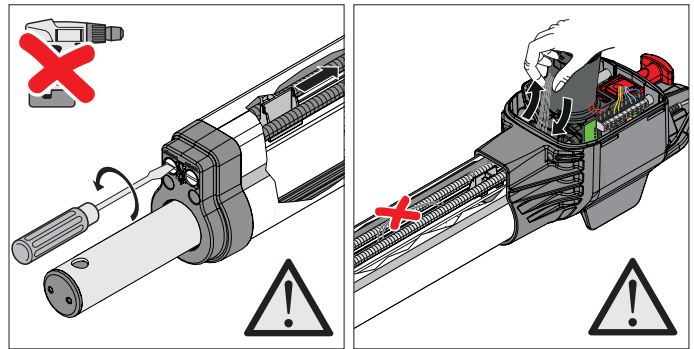

Fig. 1

Fig. 2

- 1 revolution = 1.25 mm adjustment path when adjusting the limit stops.
- When adjusting the limit stops, always insert and bundle the connecting cable to prevent individual wires becoming pinched/trapped in the housing.

NOTE

Setting the end positions achieves the following:

- The operator has maximum rigidity in the “**Gate CLOSE**” end position.
- The maximum movement range is fully used.
- Only one limit stop **must** be set to the “**Gate CLOSE**” end position.

INFORMATION

- In the installation situation “**Open gate outwards**”, the logic of the limit stops is reversed, see “**Gate opening outwards (1-/2-leaf)**” on page 25.
- The “**Gate OPEN**” end position is set via the “**close**” screw and the “**Gate CLOSE**” end position via the “**open**” screw.

6. Initial operation

1. Setting the "Gate AUF/open" end position

twist M (dimensions in mm)

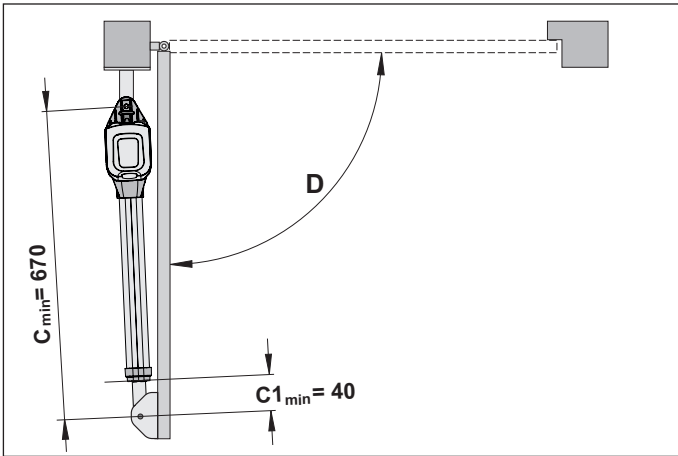

twist ML (dimensions in mm)

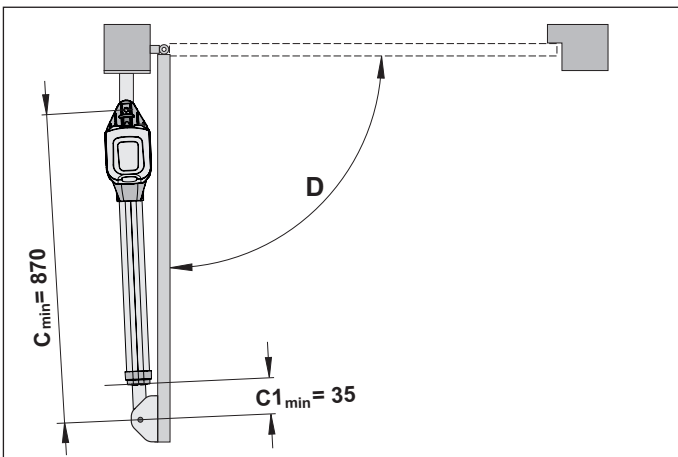

NOTE

- "Gate AUF/open" end position preset to $C1_{min}$.

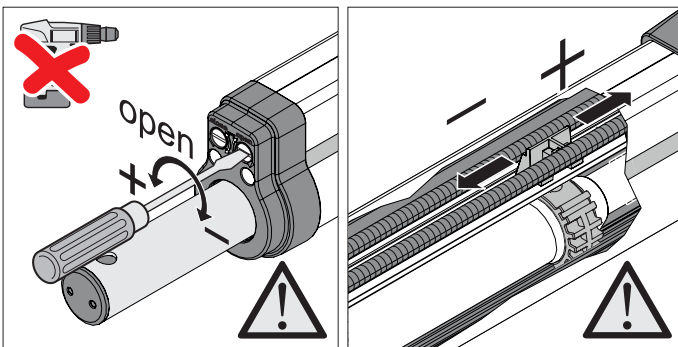

Fig. Direction of the setscrews (open) Fig. Travel length (extend/reduce)

If necessary, readjust end position with a screwdriver.

- Extend travel length
⇒ Turn "open" setscrew in (+) direction.
- Reduce travel length
⇒ Turn "open" setscrew in (-) direction.

2. Setting "Gate ZU/close" end position

twist M (dimensions in mm)

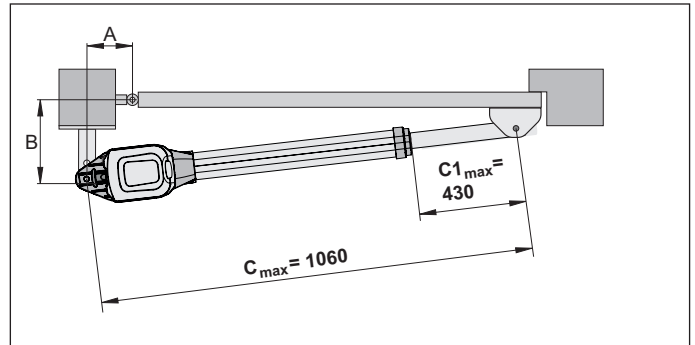

twist ML (dimensions in mm)

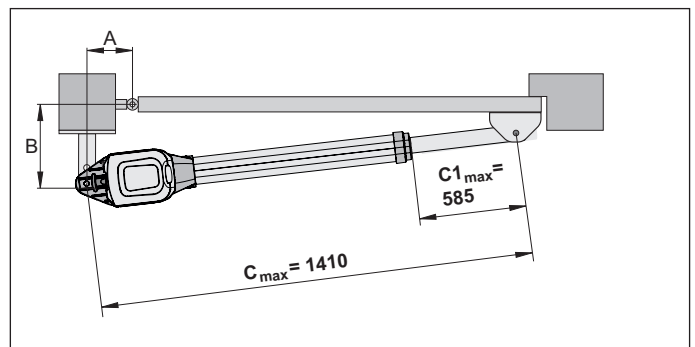

NOTE

- "Gate ZU/close" end position preset to $C1_{max}$.

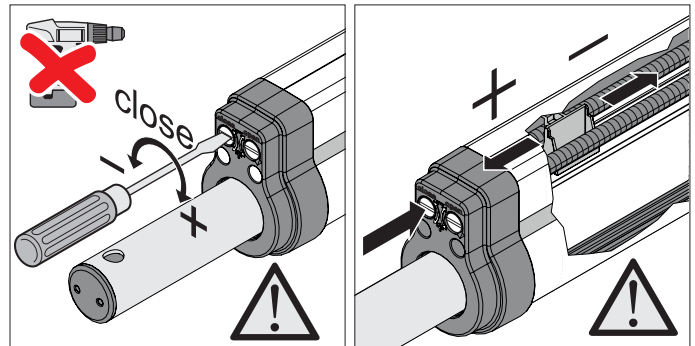
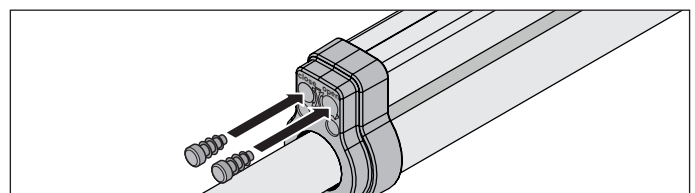

Fig. Direction of the setscrews (close) Fig. Travel length (extend/reduce)

If necessary, readjust end position with a screwdriver.

1. Extend travel length
⇒ Turn "close" setscrew in (+) direction.
2. Reduce travel length
⇒ Turn "close" setscrew in (-) direction.



- Insert lamellar plug when setting work has been completed.

6. Initial operation

6.3 Adjusting the force tolerance

⚠ CAUTION



The force tolerance settings are safety-relevant!

If the force tolerance is impermissibly high, people or animals could be injured and objects damaged.

- ▶ The adjustment of the force tolerance **must be performed by qualified personnel** and with the utmost care.
- ▶ Select a force setting that is as low as possible so that obstacles are detected quickly and safely.

Adjusting or checking the force tolerance

Force tolerance is set to the automatically programmed force. The potentiometer setting is imported again at every start.

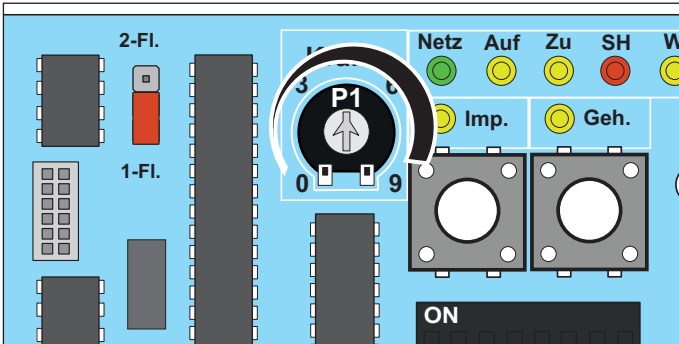

Left stop of potentiometer (0) is the lowest tolerance, the right stop (9) is the highest tolerance.

6.4 Preparing continuous operation

➔ NOTE

- **Do not use a metal object** to set the DIP switches, because this may damage the DIP switches or the circuit board.
The DIP switches **must** be set using a suitable tool, for example a flat, thin plastic object.
 - Objects in the movement area of the gate may be jammed and damaged.
Objects must not be in the range of movement of the gate.
 - The operators for 1-leaf or 2-leaf operation are connected and set, see Chapter “**4.11 Connecting operators to the control unit**” on page 24.
 - Mains power is connected and voltage (AC 230 V) is present at the control unit.
⇒ “Mains” LED on.
 - The fastening screws of the fittings are tightened, operators can be moved easily.
1. Position cover and click into place.
 2. Set emergency release lever and lock with padlock.
 3. Close the gate.
 4. Check jumper setting for 1- or 2-leaf operation. See Chapter “**5. Electrical connection**” from page 26 or “**15. Connection diagrams and functions of the DIP switches**” from page 66.

6. Initial operation

6.5 Preparing for programming

- The definitions (active leaf, inactive leaf) can be found in Chapter “3.5 Explanation of terms used” on page 12.
- The gate-side and internal end stops on the gate system are present, installed and set.
- All lines such as mains power and signal lines to the gate operator are permanently laid and connected, see Chapter “5. Electrical connection” on page 26.
- Optional safety devices, e.g. 8k2 safety contact strip, are installed and connected, see “Connecting safety devices” from page 38.
- Optional photocell is installed and connected, see “Connecting a 4-wire photocell” on page 38.
- Optional warning light is installed and connected, see “Connecting a warning light (DC 24 V)” on page 39.
- Optional buttons are connected, see “Connecting a button” on page 41 and “Connecting a key switch” on page 41.
- The factory setting of the DIP switches is “OFF” see Chapter “15. Connection diagrams and functions of the DIP switches” on page 66.
- Optional connecting cable set (7 m) is connected, see “Attaching connecting cable set (7 m)” on page 40.

6.6 Enabling continuous operation

NOTE

2-leaf gate close sequence.

- Motor 1 (M1) on the gate leaf with the stop closes first.
- Motor 2 (M2) on the gate leaf with walk-through gate closes last.

1. Check the setting of the limit stops.
2. Open and close gate.
3. If the operator switches off correctly at both end positions:
 - ⇒ Carry out programming run, see Chapter “6.7 Performing programming run” on page 34.

6.7 Performing programming run

NOTE

Check the direction of travel: After the first command, the operator **must** move in “Gate OPEN” direction.

- If the operator moves in “Gate CLOSE” direction, reverse the operator connecting cable on the control unit, see Chapter “4.11 Connecting operators to the control unit” on page 24.

INFORMATION

- Always perform learning run under supervision, because the operators traverse at full power. This is dangerous for persons, animals and objects within the range of motion of the gates.

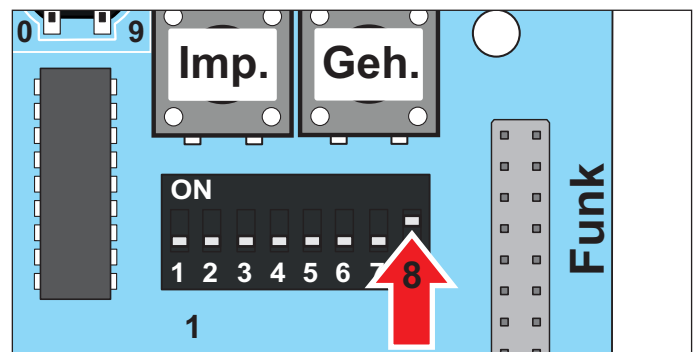

Fig. DIP switch 8 set to “ON”

1. Move the gate to centre position and lock the operator, see Chapter “4.10 Locking and unlocking the operator” on page 23.
2. Set DIP switch 8 to “ON”.
 - Connect the DIP switch during the programming run and leave it in this position during normal operation.

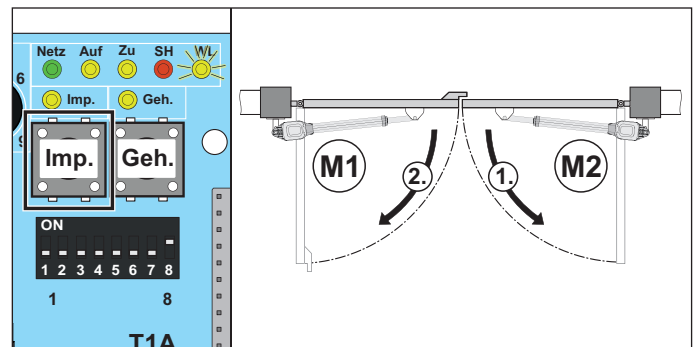

Fig. Gate OPEN

3. Press the pulse button (Imp.).
 - ⇒ Operators move into the gate “AUF/open” end position.
 - ⇒ “Mains” LED on, “WL” LED blinks.

NOTE

The operators open successively – first M2, then M1!

6. Initial operation

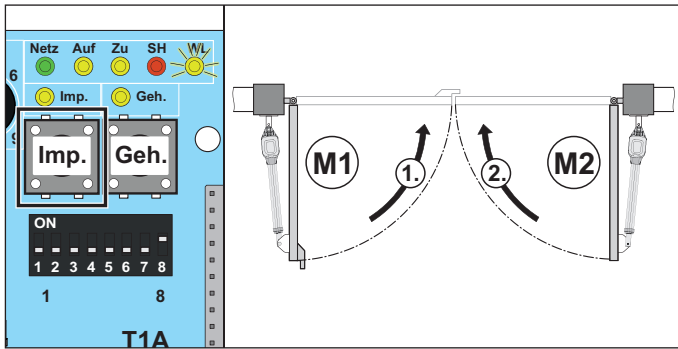

Fig. Gate CLOSE

4. Press the pulse button (Imp.).
 - ⇒ Operators move to the gate “ZU/close” end position.
 - ⇒ “Mains” LED on, “WL” LED blinks.
5. Repeat steps 3 and 4.
 - ⇒ When all values are programmed:
The “WL” LED goes out in both end positions.
6. Programming process completed.
7. After successful programming run.
 - ⇒ Operators are started and stopped with soft running. Every time the gates are opened and closed, the control unit monitors the required force, runtime, and closing delay and adjusts them incrementally when the end positions are reached.

NOTE

The operators close successively – first M1, then M2!

Detecting faulty programming runs

- ▶ Operators run without soft run.
 - ▶ The “WL” LED blinks in both end positions.
1. Reset the control unit, see Chapter “7.3 Connecting accessories” on page 38.
 2. Perform programming run.

6.8 Resetting the control unit

NOTE

The control unit reset deletes all programmed values (e.g. force values: force required by the operator to open or close the gate, closing delay).

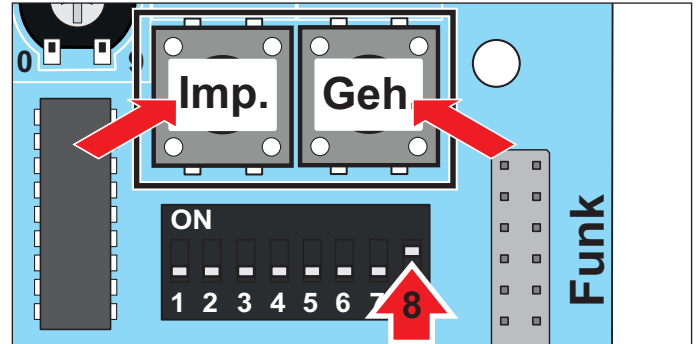

Fig. Button (Imp. + Geh.)















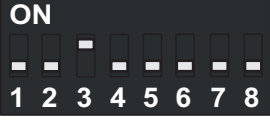

1. Simultaneously press and hold the (Imp. + Geh.) buttons.
 - ⇒ LED “WL” blinks.
 - ⇒ LED “WL” goes out after approx. 5 seconds.
 - ✓ **All values deleted.**
2. Release buttons.
 - ⇒ LED “WL” blinks.
 - ✓ **Clicking of relays can be heard.**
3. Carry out programming run, see Chapter “6.7 Performing programming run” on page 34.

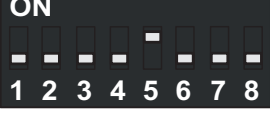
7. Connections and functions of the control unit

7.1 DIP switch

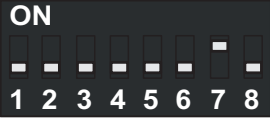
Overview of the setting options for the DIP switches

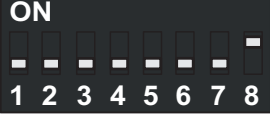
Do not use metal objects to set the DIP switches, because this may damage the DIP switches or the circuit board.

DIP switch	Function	Effect
1 	ON Response to triggering the safety input (terminals 17 + 18) while the gate opens.	• The gate stops
	OFF  Response to triggering the safety input (terminals 17 + 18) while the gate opens.	• No reaction
2 	ON Response to triggering the safety input while the gate closes.	• The gate stops
	OFF  Response to triggering the safety input while the gate closes.	• Gate reverses
3 	ON DIP 2 = OFF	• Gate opens completely
	OFF  DIP 2 = OFF	• Gate reverses
4 	ON Warning light blinks	
	OFF  Warning light on	
5 	ON Pre-warning time warning light	• 3 seconds • Warning light blinks or lights up before gate starts moving, depending on the position of DIP 4
	OFF  Pre-warning time warning light	• OFF
6* 	ON Fully automatic closing function	
	OFF  Manual operation/semi-automatic closing	
7* 	ON Fully automatic closing function with shorter hold open time after drive-through of the photocell (depending on position of DIP 6). Semi-automatic closing function with shorter hold open time after drive-through of the photocell (depending on position of DIP 6).	• 5 seconds
	OFF  No function	
8 	ON Continuous operation/operator learns continuously while the gate opens and closes.	• Force values – runtime – closing delay
	OFF  Test mode	• Operator does not learn any values • Setting the limit stops
8 → NOTE	Leave DIP switch 8 “ON” after a programming run. OFF position immediately deletes all saved values.	



Factory setting

* For additional settings, see TorMinal operating manual.

7. Connections and functions of the control unit

7.2 Automatic closing

There are two basic variants for automatic closing: fully/semi-automatic closing function. When both variants are activated at the same time, the fully automatic closing function has priority.

NOTE

- When using the automatic closing function, ensure compliance with standard EN 12453 (e.g. install a photocell).

INFORMATION

- Install a switch in the photocell supply wire for manual interruption of automatic closing.
- The reaction of the safety devices depends on the DIP switch settings.

Fully automatic closing function

When fully automatic closing is activated, the gate is opened by a pulse. The gate moves to the gate OPEN end position.

The gate closes automatically after the hold open time (OHZ).

DIP 6	ON
TorMinal	Sets the OHZ (5–255 seconds, factory setting 60 seconds)
DIP 7	OFF

The set hold open time of the gate is 60 seconds. Every new command within these 60 seconds restarts the hold open time.

1. If button 1 on the transmitter is pressed, the gate moves to gate OPEN end position. The gate movement cannot be stopped with the transmitter.
2. After 60 seconds, the gate closes automatically. The closing movement can be stopped by a command with the transmitter.
⇒ Gate opens completely – after reversal of direction.
3. The gate starts the closing process again after 60 seconds.
⇒ Gate CLOSE.

Shortened hold open time

When driving through, the photocell is activated and the hold open time is shortened to 5 seconds.

DIP 6	ON
DIP 7	ON
TorMinal	Sets shortened OHZ (1–20 seconds, factory setting 5 seconds)

Semi-automatic closing function

When semi-automatic closing is activated, the gate is opened by a pulse. The gate moves to the gate OPEN end position. The gate closes automatically after the hold open time. Incoming commands end the hold open time. The operator can be actively moved at any time with a command.

DIP 6	OFF
TorMinal	Sets the OHZ (5–255 seconds, factory setting 60 seconds)
DIP 7	ON
TorMinal	Sets shortened OHZ (1–20 seconds, factory setting 5 seconds)

The set hold open time of the gate is 60 seconds. Every new command within these 60 seconds ends the hold open time, and the gate closes immediately.

1. If button 1 on the transmitter is pressed, the gate moves to gate OPEN end position.
2. After 60 seconds, the gate closes automatically. The closing movement can be stopped by a command with the transmitter.
⇒ The gate stops.
3. If button 1 on the transmitter is pressed, the gate moves to gate OPEN end position again.
⇒ The gate starts the closing process again after 60 seconds.
⇒ Gate CLOSE.

7. Connections and functions of the control unit

7.3 Connecting accessories

Connecting safety devices

To ensure correct functioning, photocells and safety devices must be correctly mounted and connected before initial operation.

Only a 4-wire photocell can be connected at the safety input. We recommend installing the photocell at a height of up to 300 mm.

To protect property, it may be necessary to install an additional photocell at a height of approx. 600 mm. on the inside and outside. Only photocells with 4-wire technology can be connected in series.

WARNING



Danger of crushing and shearing!

If the gate moves, crushing and shearing injuries may be caused by the mechanism and safety edges of the gate.

- ▶ In accordance with EN 12453, a photocell **must** be installed at a height of up to 300 mm to protect persons.
- ▶ Always keep the moving gate in sight.
- ▶ Keep persons and animals clear of the range of movement of the gate.
- ▶ Never put your hand near the gate when it is moving or near moving parts.

NOTE

- It may be necessary to install a second photocell inside and outside at an installation height of e.g. 600 mm. This makes it possible to secure larger vehicles, for example.

Connecting a 4-wire photocell

NOTE

- When using the automatic closing function, ensure compliance with standard EN 12453 (install a photocell).
- **Connection of a 2-wire photocell is not possible.**

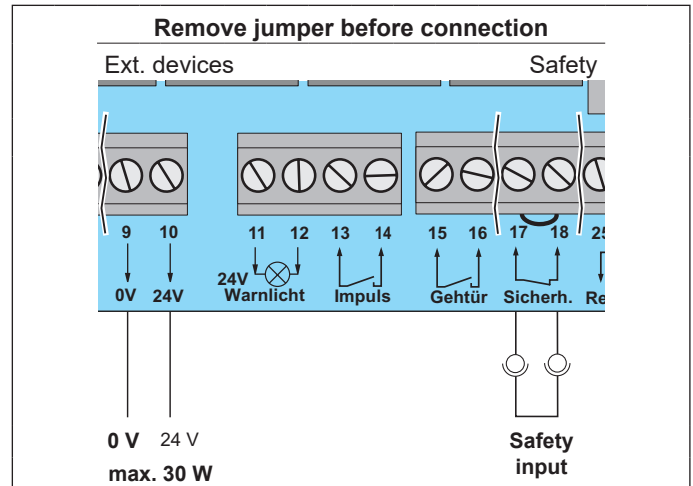

Terminal	Designation	Description
9	0 V	DC 24 V output with max. 30 W power (unstabilised DC 22–32 V).
10	24 V	
17	Safety	Safety device connection
18		

INFORMATION

- Only use the connection for potential-free NC contacts. External voltage can trigger severe power surges and damage or destroy the control unit.

7. Connections and functions of the control unit

Connecting a warning light (DC 24 V)

Setting the functions – DIP switches 4 + 5, see table “Overview of the setting options for the DIP switches” on page 66.

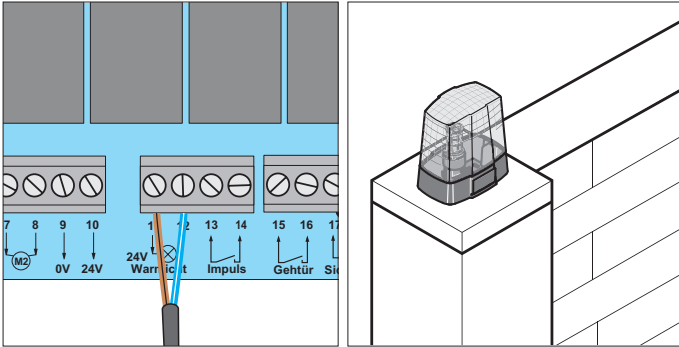

Fig. Terminal block

Fig. Warning light 24 V

A warning light with (DC 22 V–32 V, max. 25 W) can be connected. The polarity is optional. The warning light lights up during normal operation (factory setting DIP 4 “OFF”).



INFORMATION

- The voltage for the warning light is the direct and unregulated transformer voltage. The voltage can fluctuate between 22 V and max. 32 V.

Terminal	Designation	Description
11	24 V warning light	Connection for DC 24 V warning light with max. 25 W power (unstabilised DC 22-32 V).
12		

Connecting an external device

NOTE

An external device is operated with direct-current, unregulated transformer voltage. The transformer voltage can fluctuate between DC 22–32 V under full load.

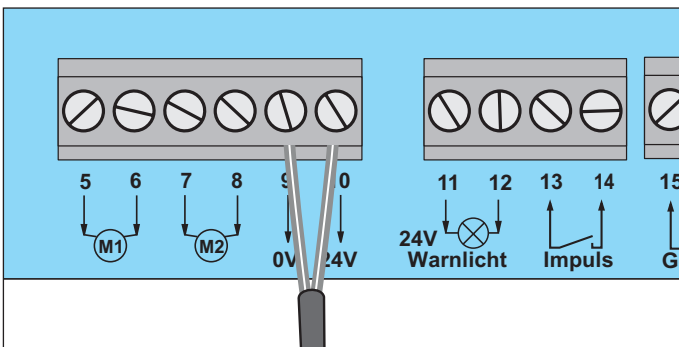

Terminal	Designation	Description
9	0 V	DC 24 V output with max. 30 W power (unstabilised DC 22-32 V).
10	24 V	

Connecting a floating relay contact

NOTE

- Operate under ohmic load only. Only electric locks from **SOMMER Antriebs- und Funktechnik GmbH** may be used.

Check for the correct polarity.

If other types of electric locks are used, the guarantee for the motor control unit will be rendered void.

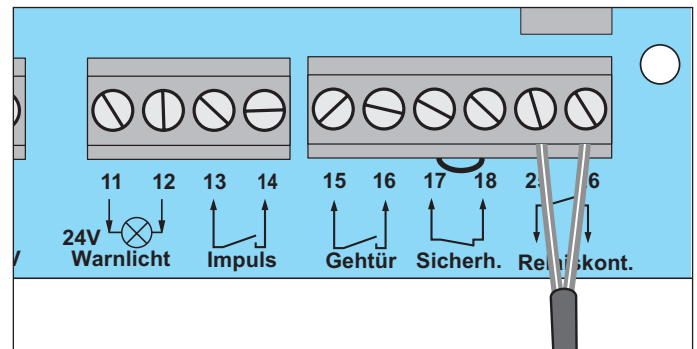

Terminal	Designation	Description
25	Relay contact	Connection, e.g. electric lock max. DC 24 V.
26		

7. Connections and functions of the control unit

Connecting an electric lock (DC 24 V)

NOTE

- This connection diagram is **only** valid for a DC 24 V electric lock.
- DC 12 V electric locks may **only** be connected after consulting the manufacturer.
- Only electric locks from **SOMMER Antriebs- und Funktechnik GmbH** may be used. Check for the correct polarity.
- If other types of electric locks are used, the guarantee for the motor control unit will be rendered void.

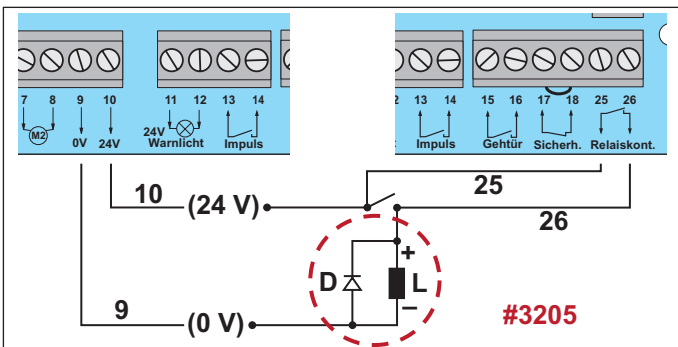
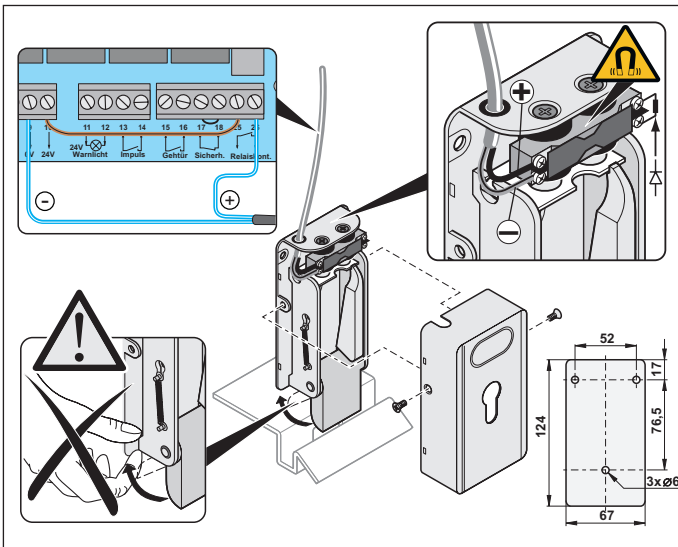

Only an electric lock (DC 22 V–32 V) can be connected.

Terminal	Designation	Description
9	0 V	DC 24 V output with max. 30 W power (unstabilised DC 22-32 V).
10	24 V	

INFORMATION

- The voltage for the electric lock is the direct and unregulated transformer voltage. The voltage can fluctuate between 22 V and max. 32 V.

Attaching connecting cable set (7 m)

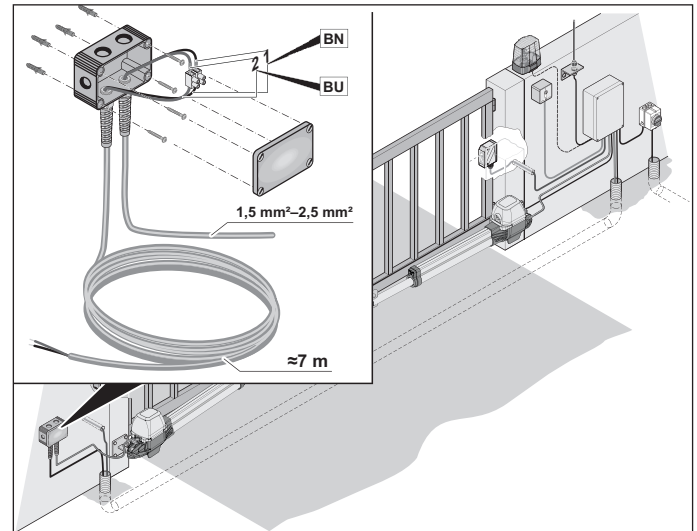

1. Attach the junction box appropriately for the respective supporting surface (e.g. concrete, masonry, wood, etc.).
2. Connect cables with the same numbers:
 - blue with blue
 - brown with brown
 - etc.
3. Tighten cable glands well to prevent ingress of moisture into the junction box.
4. Close junction box.

7. Connections and functions of the control unit

Connecting a button

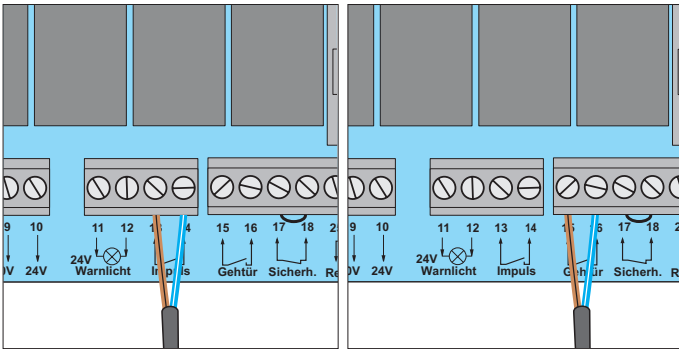

Fig. Button 1

Fig. Button 2

1-contact button

- 1-leaf gate system buttons at terminal 13 + 14 or 15 + 16
- 2-leaf gate system buttons at terminal 13 + 14

2-contact button

- Walk-through gate, terminal 15 + 16
- Both gate leaves, terminal 13 + 14

Terminal	Designation	Description
13	Pulse	Connection for pulse transmitter for actuating one or both gate leaves.
14		
15	Walk-through gate	Connection for pulse transmitter for actuating a gate leaf.
16		



INFORMATION

- Only use the connection for potential-free NO contacts. External voltage can trigger severe power surges and damage or destroy the control unit.

Connecting a key switch



- To prevent control unit faults, never lay the cable of the key switch along a power line.
- Fix the switch cable firmly in place.
- Install key switch in an easily accessible position.

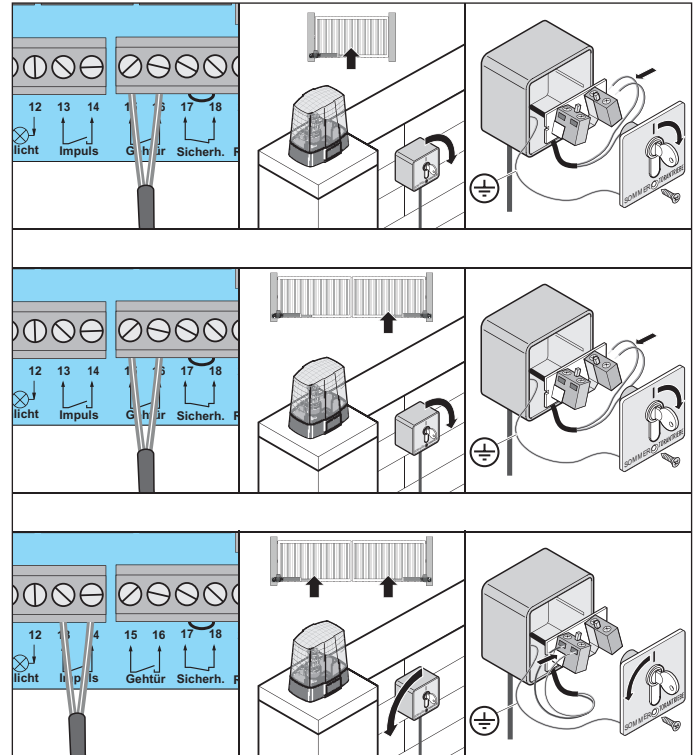

INFORMATION

- When operating the key switch, the user must not stand within the range of movement of the gate and **must** have a direct view of it.

7. Connections and functions of the control unit

Connecting an accumulator

An accumulator can supply power during a mains power failure. The accumulator can only be recharged for a limited number of cycles. This depends on the use and settings. Mains voltage is required for initial operation of the operator.

Only a **qualified electrician** is permitted to connect, install, test and replace the accumulator.

Observe the information in the separate “**Accessories, description**” for the respective accumulator.

Accumulators from **SOMMER Antriebs- und Funktechnik GmbH** are intended exclusively for use in combination with SOMMER products.

⚠ WARNING

Danger of fire, explosion or burns!



Improper storage, use or disposal of accumulators or batteries are dangerous for the health of humans and animals. Serious injury or death may result.



▶ Do not take apart, do not heat to above 60 °C or burn.



▶ During replacement, observe the installation position and polarity of the accumulators.

▶ Components that have been taken out of service, old accumulators and batteries must not be disposed of with household waste. Components which are no longer in use, old accumulators and batteries must be disposed of properly. The local and national regulations must be observed.

After a power failure, the accumulator is automatically recharged via the control unit as soon as the mains voltage supply is restored.

Depending on the specific requirements, the following accumulator variants are available.

Accumulator type	Capacity	Running time	Maximum
Accu	700 mAh	6 h	3 gate cycles
Accu 2.2	2,200 mAh	20 h	5 gate cycles

➔ NOTE

• All technical data are based on an ambient temperature of +20 °C/+68 °F.

The performance data of an accumulator/battery pack are influenced by its specific external operational conditions.

For example, the ambient temperature, current consumption, state of charge, number of charging cycles as well as the age of the accumulator/battery pack can significantly change the performance data.

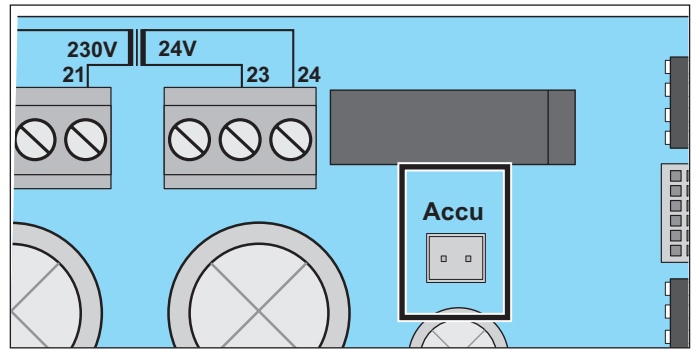

Fig. Connection for accumulator



INFORMATION

- When operating the key switch, the user must not stand within the range of movement of the gate and **must** have a direct view of it.
- The accumulator is connected to the circuit board. They **must** be disconnected before carrying out work on the operator, to prevent damage to the control unit.
- The accumulator is not charged in as-delivered state.

7. Connections and functions of the control unit

7.4 Operator lighting (LED)

The operator lighting is optional.

The optional operator lighting (LED) is located on the underside of the operator housing.

LED lighting in the lower housing section

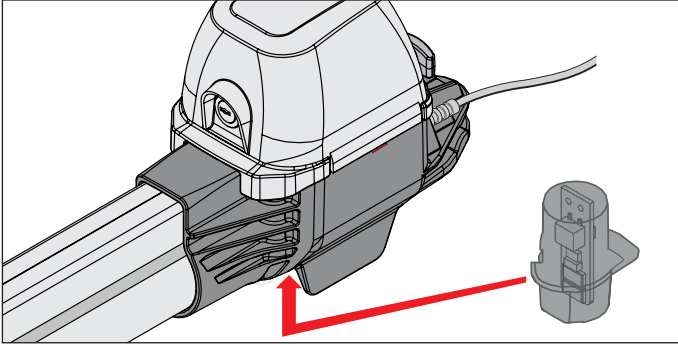

Fig. LED lighting – operator housing (underside)

The LED lighting is **(optional)** depending on the specific operator type. If LED lighting is present, see Chapter “7.5 Connections of the motor PCB” on page 43.

The LED lighting function of the operator switches on automatically during opening and closing of the gate system. In the respective end positions gate “AUF/open” and gate “ZU/close”, the LED lighting function switches off automatically.

NOTE

Defective or damaged LED lighting should be repaired by a specialist company.

- All work on electrical components must be carried out by a **trained electrician**.

Sealing plug in the lower housing section

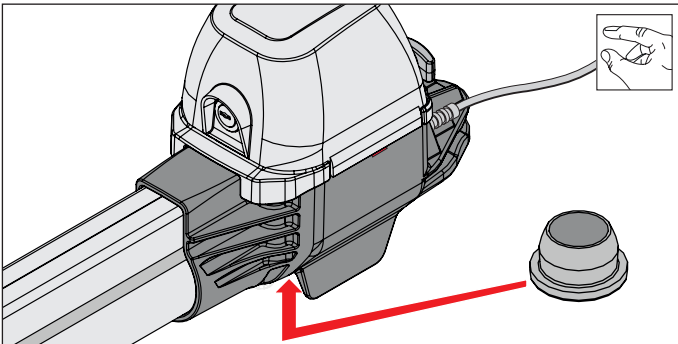

Fig. Sealing plug – operator housing (underside)

The sealing plug on the underside of the operator is used to close off the LED lighting mount when the LED lighting is not used.

7.5 Connections of the motor PCB



INFORMATION

- The first gate movement **must** always be gate OPEN. Otherwise, the cable colours for the motor (blue/black) must be reversed.

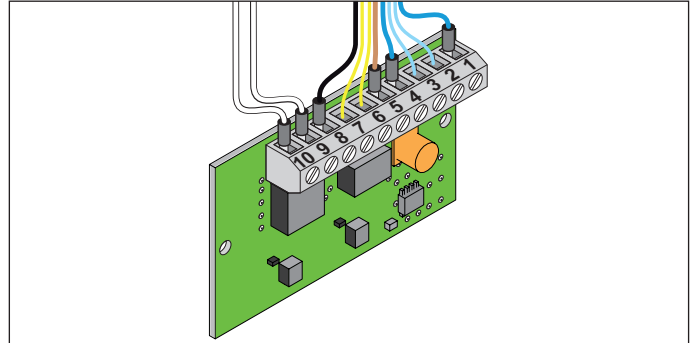

Terminal	Description	Cable colour
1	24 V feed line from control unit	blue
2	Gate “ZU/close” limit stop	blue
3	Gate “ZU/close” limit stop	blue
4	Motor	blue
5	24 V feed line from control unit	brown
6	Gate “AUF/open” limit stop	yellow
7	Gate “AUF/open” limit stop	yellow
8	Motor	black
9	Lighting	white
10	Lighting	white

8. Radio remote control

8.1 Installing the radio receiver

Slot for SOMUp4 S2 on the circuit board

NOTE

The SOMUp4 can only be plugged into the control unit circuit board in one direction.

- Plug it in carefully.
- Do not use force.

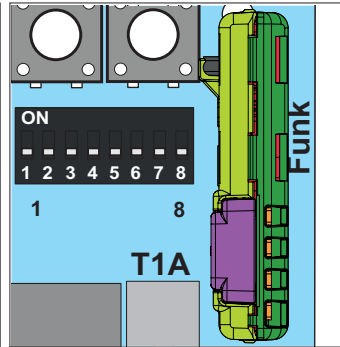
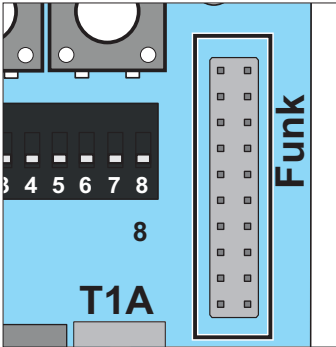
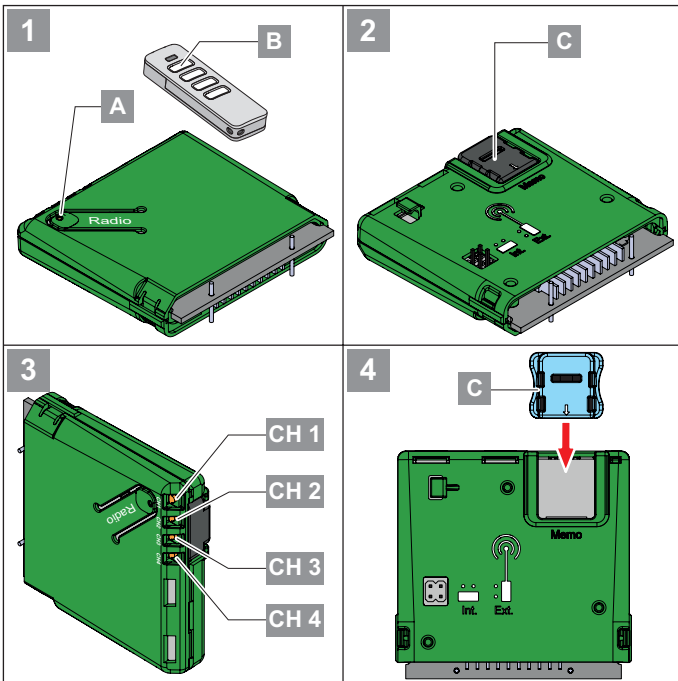

Fig. 1 Empty slot

Fig. 2 SOMUp4 S2 plugged in

Always observe when replacing the SOMUp4 S2!

8.2 Explanation of display and buttons, SOMUp4 S2



8.3 Explanation of the radio channels

LED	channel	Description
CH 1	1	Same function as "Start 1" (pulse)
CH 2	2	Same function as "Start 2" (active leaf)
CH 3	3	No function
CH 4	4	No function

8.4 Selection of the radio channels

	1x	2x	3x	4x
LED				
CH 1				
CH 2				
CH 3				
CH 4				

1. Press the Radio button (A) on the control unit repeatedly to select the desired radio channel (CH).

NOTE

- If no button is detected as pressed on the handheld transmitter within 30 seconds, the LED for the selected radio channel (CH) goes out and programming mode is ended.

8.5 Programming the transmitter

NOTE

- The transmitter that is to be programmed **must** be located near the receiver during the programming process!

1. Press button (A) briefly.
 - 1x for channel 1, ⇒ LED CH 1 lights up green.
 - 2x for channel 2, ⇒ LED CH 2 lights up green.
 - 3x for channel 3, ⇒ LED CH 3 lights up green.
 - 4x for channel 4, ⇒ LED CH 4 lights up green.
 - ⇒ If no command is transmitted within 30 seconds, the radio receiver switches over to normal mode.
 - ⇒ Cancelling programming mode: Press the Teach-in button (A) repeatedly until no more LEDs are lit.
2. Press and hold the desired handheld transmitter button (B) until the LED for the selected channel blinks quickly and goes out.
 - ✓ Programming is finished.
3. Repeat steps 1–2 to program other handheld transmitters to this radio receiver.

8. Radio remote control

8.6 Cancelling programming mode

1. Press the Radio button **(A)** on the control unit repeatedly until the LED for the selected radio channel goes out, or do not make an entry for 30 seconds.
 - ⇒ Programming mode is cancelled.

8.7 Deleting a transmitter from the radio channel

1. Select radio channel with button **(A)** and hold the button pressed for 15 to 20 seconds until the LED for the selected channel flashes red.
2. Release Teach-in button **(A)**.
 - ⇒ To cancel delete mode: Press button **(A)**, LED goes out.
 - ⇒ If no command is transmitted within 30 seconds, the radio receiver switches over to normal mode.
3. On the transmitter, press the button for which the command is to be deleted in the radio receiver.
 - ⇒ LED blinks quickly – delete complete.
 - ⇒ Radio receiver switches to normal mode,
 - ✓ **Deletion has been completed.**

8.8 Deleting a transmitter from the radio receiver

1. Press and hold button **(A)** for 20 to 25 seconds until LED **(CH 1)** blinks red.
2. Release button **(A)**.
 - ⇒ To cancel delete mode: Press button **(A)**, LED **(CH 1)** goes out.
 - ⇒ If no command is transmitted within 30 seconds, the radio receiver switches over to normal mode.
3. Press any button on the transmitter that is to be deleted from the receiver memory.
 - ⇒ Radio receiver deletes the transmitter, LED **(CH 1)** blinks quickly.
 - ⇒ Radio receiver switches to normal mode.
 - ✓ **Deletion has been completed.**

8.9 Deleting a radio channel in the receiver

➔ **NOTE**

- This action cannot be interrupted!

1. Select the radio channel to be deleted with button **(A)** and hold button **(A)** pressed for 25–30 seconds until the LED for the selected channel lights up red.
2. Release button **(A)**.
 - ⇒ The channel is deleted from the radio receiver.
 - ⇒ Receiver switches to normal mode.
 - ✓ **Deletion has been completed.**

8.10 Delete all radio channels in the receiver

➔ **NOTE**

- This action cannot be interrupted!

If a transmitter is lost, all channels in the radio receiver **must** be deleted for security reasons! Then reprogramme all transmitters.

1. Press and hold button **(A)** for more than 30 seconds until the LEDs (CH 1–CH 4) simultaneously light up red.
2. Release button **(B)**.
 - ⇒ Radio receiver deletes the memory.
 - ⇒ Radio receiver switches to normal mode.
 - ✓ **Deletion has been completed.**

8. Radio remote control

8.11 Programming by radio (HFL)

Function

Each handheld transmitter that has already been programmed can put the receiver into programming mode by radio. This allows additional transmitters to be programmed without having to press button (A) on the receiver. The button assignment on handheld transmitter A (Fig. HFL) (which activated the receiver) is also used for handheld transmitter (B) which needs to be programmed. Both handheld transmitters must be located within the range of the radio receiver.

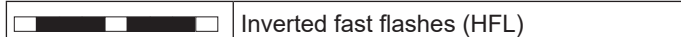

Inverted fast flashes (HFL)

NOTE

- Only the programming of identical handheld transmitters by radio is recommended!
If different handheld transmitter types are used, only the first button command is transferred from handheld transmitter 1 to handheld transmitter 2.

Procedure

1. Press and hold buttons (1+2) of the previously programmed handheld transmitter **A** for 3–5 seconds until LEDs (CH 1 and CH 2) on the receiver fast flash inverted green.
2. Release buttons (1+2).
 - ⇒ If a command is not transmitted within another 30 seconds, the radio receiver switches over to normal mode.
3. Press any button on the new handheld transmitter **B**.
 - ⇒ LEDs (CH 1–CH 4) on the receiver blink quickly and go out.
 - ⇒ Commands and key assignment on handheld transmitter **B** and handheld transmitter **A** are now identical.

Operation

1. Press transmitter button (B) briefly.
 - ⇒ LED for the programmed channel lights up orange as long as the button is pressed.
 - ⇒ The assigned output switches.

8.12 Information on Memo

The memory capacity can be extended to 450 handheld transmitter commands using the optional Memo accessory part. When the Memo is plugged in, all available transmitters are transferred from the internal memory to the Memo and stored there. The Memo **must** remain plugged in on the control unit.

No more transmitters are then stored in the internal memory. Stored transmitters cannot be transferred from the Memo back to the internal memory.

All radio channels, including the memory of the Memo, can be deleted.

The Memo can also be used for transmitter management with Codemaster+.

INFORMATION

- Only delete a Memo on which data has been stored on a new operator or via Codemaster+ Otherwise, all stored transmitters of the operator are deleted and must be reprogrammed.

Installing the Memo

NOTE

- If the Memo is removed, the receiver memory is empty. Radio commands need to be programmed again!

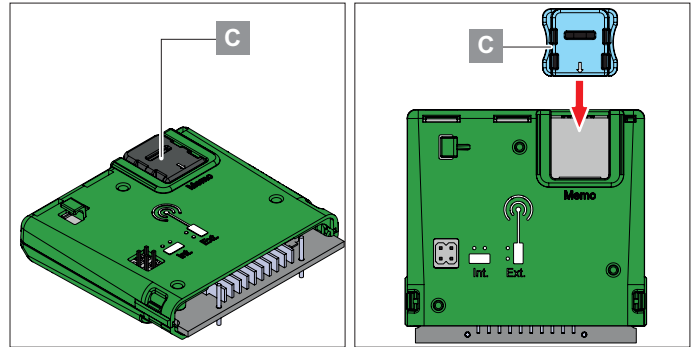

Fig. Memo slot

Fig. Plug-in direction

1. Turn off the power supply to the operator control unit.
2. Disconnect the receiver from the operator control unit.
3. Plug the Memo (C) into the slot.
4. Reconnect the receiver to the operator control unit.
5. Restore the voltage supply.
 - ⇒ A total of 450 memory locations is now available for radio commands.

Important note for more detailed information

You can get the separate Installation and Operating Manual (radio receiver SOMup4 – SOMloq2/868.95 MHz) by scanning the QR code.



<https://downloads.sommer.eu/?category=36>

8. Radio remote control

8.13 Antenna connections

Jumper (slots)

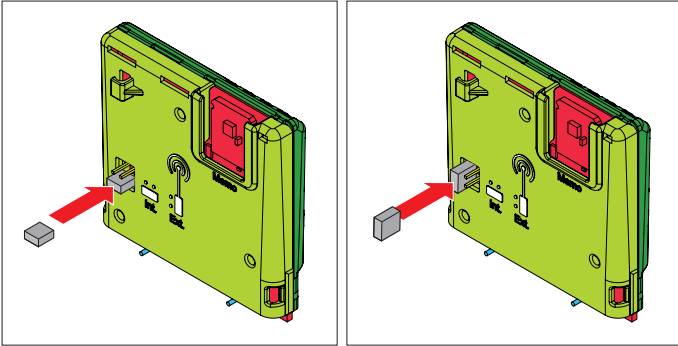

Fig. 1 Internal jumper

Fig. 2 External jumper

1. Jumper slot on the SOMup4 S2 when using **the integrated** antenna.
2. Jumper slot on the SOMup4 S2 when using **the external** antenna.

External antenna

→ NOTE

If the range of the internal antenna (integrated on the SOMup4 S2) is insufficient, connect an external antenna.

Agree on the installation location of the antenna with the user of the gate system.

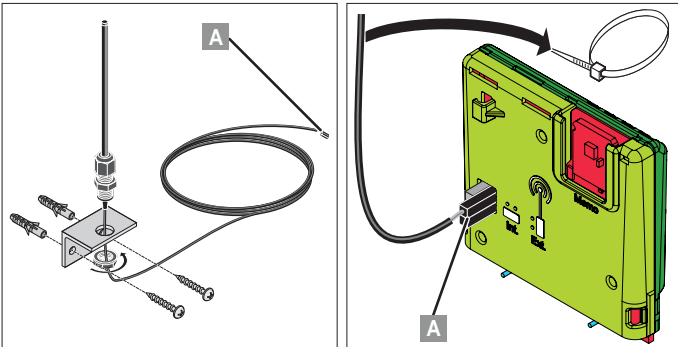

Fig. 1 External antenna

Fig. 2 Connection

1. Installation example for mounting of the antenna (e.g. masonry or concrete walls).
2. Attach plug of the external antenna.
3. Attach a strain relief on the antenna cable to prevent mechanical stresses on the radio receiver. The strain relief **must** be attached to the control unit housing to prevent damage to the SOMup4 S2!

9. Function test – final test – handover

9.1 Checking the obstacle detection

→ NOTE

- The national standards, guidelines and regulations for cut-off of the operating forces **must** be observed.
- The obstacle detection **must** be tested once a month to prevent damage to the operator.
- Obstacle detection requires a correctly completed programming run.

DANGER



Danger if not observed!

If warnings are not observed, serious injury or death may result.

- ▶ All warnings must be complied with.
- ▶ In addition, observe the safety instructions in Chapter “**2. General safety instructions**” from page 9.

WARNING



Danger of entrapment!

If the force setting is too high, persons or animals in the movement area of the door may be trapped by the door. Severe injuries or death may result.

- ▶ Check the obstacle detection once a month.

INFORMATION

- After installing the operator, the person responsible for the installation **must** complete a Declaration of Conformity for the entire gate system in accordance with the directives applicable in the respective location and attach the corresponding marking.

In member states of the European Union
Machinery Directive 2006/42/EC + CE mark.

In Great Britain

Supply of Machinery/Safety Regulations 2008 + UKCA mark.

This documentation and this installation and operating manual must be handed over to the user.

This also applies if the operator is retrofitted to a manually operated gate.

- If a photocell is interrupted, the gate reverses.
- If an obstacle is encountered, the operator stops and reverses fully or partially, depending on the setting and operating mode.

INFORMATION

- In accordance with EN ISO 13849-1, all safety-relevant equipment affecting the safety of the gate system **must** meet the requirements of at least PL “C” Cat. 2!

Our range includes various safety strips. It includes both active (trigger an immediate stop of the gate at contact) and passive (take up part of the inertial mass of the moving gate) strips.

Obstacle detection by photocell

→ NOTE

- A photocell must not be used for personal protection!
- A photocell must be used for object protection only.

The tolerance for the force required for opening and closing can be set via the potentiometers.

If the force required increases or decreases within the set tolerance, the control unit automatically learns this value.

If the force required is outside the set tolerance (e.g. due to an obstacle), the operator stops and reverses a short distance. Obstacle detection with reversing is required for safety.

9.2 Checking the force setting

The force settings must be tested with a force measurement device. Additional safety equipment such as photocells or safety contact strips **must** then be tested for correct functioning.

If this is not the case, a reset **must** be carried out, see Chapter “**7.3 Connecting accessories**” on page 38.

The positions and the forces must be reprogrammed, see Chapter “**6.3 Adjusting the force tolerance**” on page 33 and “**6.8 Resetting the control unit**” on page 35.

INFORMATION

- After successful testing of the force settings, the obstacle detection and the functions, the **qualified specialist must** attach the CE mark/UKCA mark and the type plate to the gate.

9. Function test – final test – handover

9.3 Handover of the gate system

The qualified specialist must instruct the user:

- on the operation of the operator and its dangers
- on the handling of the manual emergency release
- on the regular maintenance, testing and care measures which the user can carry out, see Chapter “**11. Maintenance and care**” on page 54.
- on the troubleshooting measures which the user can carry out, see Chapter “**12. Troubleshooting**” on page 56.

The user must be informed about which work may only be performed by a qualified specialist:

- installation of accessories
- settings
- regular maintenance, testing and care, except that described in Chapter “**11. Maintenance and care**” on page 54
- troubleshooting, except that described in Chapter “**12. Troubleshooting**” on page 56
- repairs

The following documents for the door system must be handed over to the user:

- the installation and operating manuals for the entire gate system
- Inspection book
- EC Declaration of Conformity
- handover protocol for the control unit/operator(s)



<https://som4.me/konform>



INFORMATION

- Keep this Installation and Operating Manual accessible at all times at the place of use.

10. Operation

10.1 Important notes and information

In particular, observe the following warnings and Chapters “11. Maintenance and care” on page 54 and “12. Troubleshooting” from page 56.

DANGER



Danger if not observed!

If warnings are not observed, serious injury or death may result.

- ▶ All warnings must be complied with.
- ▶ In addition, observe the safety instructions in Chapter “2. General safety instructions” from page 9.

WARNING



Danger due to use of the operator with incorrect settings or when it is in need of repair!

If the operator is used despite incorrect settings or if it is in need of repair, severe injury or death may result.

- ▶ The operator may only be used with the required settings and in the proper condition.
- ▶ You must have faults repaired professionally without delay.



Danger of crushing and shearing!

If the gate moves and there are persons or animals in the movement area, crushing and shearing injuries may be caused by the mechanism and safety edges of the gate.

- ▶ Only use the operator when you have a direct view of the gate.
- ▶ All danger zones must be visible during the entire gate operation.
- ▶ Always keep the moving gate in sight.
- ▶ Keep persons and animals clear of the range of movement of the gate.
- ▶ Never put your hand near the gate when it is moving or near moving parts. In particular, do not reach into the moving push arm.
- ▶ Do not drive through the gate until it has opened completely.
- ▶ Never stand in the opened gate.

NOTE

- If the gate is incorrectly set, the operator may be damaged.
 - The gate **must** be stable.
 - It must not bend, rotate or twist when opening and closing.
 - The gate **must** move easily.

Defects must be repaired without delay by a **qualified specialist**.

- Objects in the movement area of the gate may be jammed and damaged.
Objects must not be in the range of movement of the gate.

Normal mode

Changes to the gate affect the force needed for opening and closing.

Examples of changes to the gate:

- Damage
- Moisture absorption
- Ground submergence
- Changes in the weather in summer-winter mode
- Obstacles

Summer mode – winter mode

Differences in weather between summer and winter can influence the operators:

- The force required varies for opening and closing.
- The gate reverses without a noticeable obstacle.
- The end positions of the gate leaves change.

If the gate will not open or close or reverses without a noticeable obstacle:

1. Reset the control unit, see Chapter “6.8 Resetting the control unit” on page 35.
2. Carry out programming run, see Chapter “6.7 Performing programming run” on page 34.

If the end positions have changed:

- ⇒ Adjust limit stop.

10. Operation

10.2 Operating modes of gate movement

In the following description of the gate movement, it is assumed that buttons 1–4 on the handheld transmitter have been assigned to radio channels CH 1–4. With 2-leaf gates, the movements of the two gate leaves start with a time delay.

⚠ WARNING

Danger of injury during gate operation!



Gates can injure people or animals in the movement area of the gate when the gate is closing. This may cause crushing or shearing injuries.



- ▶ In particular when operating control elements, all danger zones must be visible during the entire gate operation.
- ▶ Keep persons and animals clear of the range of movement of the gate.
- ▶ Always keep the moving gate in sight.
- ▶ Never put your hand near the gate or near moving parts when the gate is moving.
- ▶ Do not drive through the gate until it has opened completely.
- ▶ Never stand in the opened gate.



INFORMATION

- Reversing: The operator stops when it hits an obstacle. The gate then moves slightly in the opposite direction to release the obstacle. In the automatic closing function, the gate opens completely.
- In the event of interruption of the photocell, the run-on time is longer than when the gate hits an obstacle.

The following safety devices are installed to detect obstacles:

- obstacle detection of operator (personal protection)
- safety contact strips (personal protection)
- photocell (object protection)

10.3 Overview of gate movements opening and closing gate

Requirements

- DIP switch 8 to ON.
- Programming run performed.
- Transmitter programmed.
 - ⇒ Button 1 on channel K1.
 - ⇒ Button 2 on channel K2.

1-leaf gate

Open and close active leaf

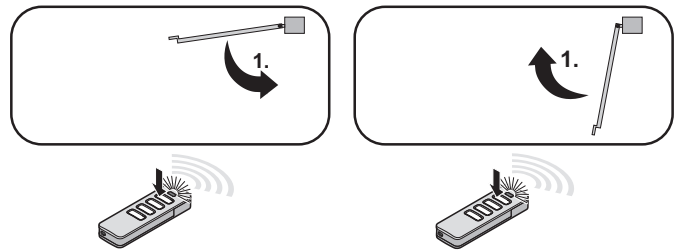

Pulse sequence of button 1 on the handheld transmitter

2-leaf gate

Open and close gate leaves

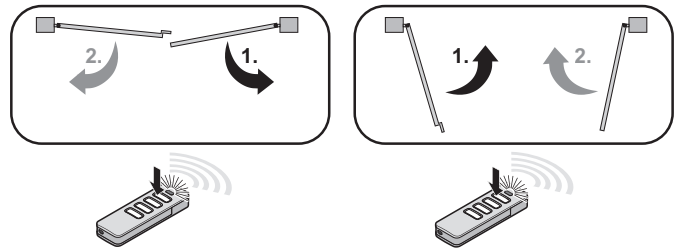

Pulse sequence of button 1 on the handheld transmitter

Open and close active leaf

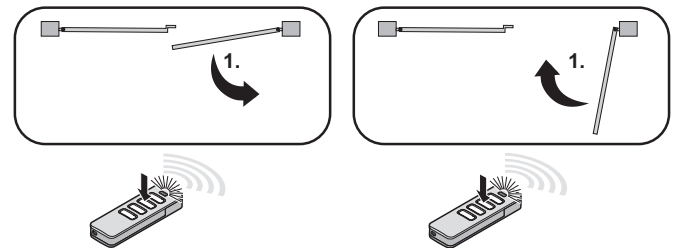

Pulse sequence of button 2 on the handheld transmitter

10. Operation

10.4 Obstacle detection

The operator stops and reverses slightly if it encounters an obstacle. This prevents injury and damage to property. The gate will be partially or completely opened, depending on the setting. The partial reversion is pre-set at the factory.

10.5 In the event of a power failure

The programmed force and position values are retained in the event of a power failure. The first movement of the operator after the power supply returns is always gate OPEN.

After a power failure, the gate operator reacts as follows when a button is pressed:

- With a 1-leaf gate system, the active leaf starts up.
- With a 2-leaf gate system, the active leaf opens completely and then the inactive leaf opens.
- The warning light continues to blink after opening.
- If the button on the handheld transmitter is pressed again, the operator once again tries to drive in gate OPEN direction.
- When the button on the handheld transmitter is pressed again, the gate system closes.

Also observe the instructions for emergency release in Chapter “**10.6 Function of the emergency release**” on page 52.

Emergency release in the event of power failure

See Chapter “**4.10 Locking and unlocking the operator**” on page 23.

Battery operation in the event of a power failure

Also observe the instructions on battery operation in Chapter “**7. Connections and functions of the control unit**”, in section “**Connecting an accumulator**” on page 42.

10.6 Function of the emergency release

In the event of a power failure, the gate can be opened from the inside using a mechanical emergency release.

WARNING



Danger of crushing and shearing!

If the gate is opened with the emergency release lever, the gate can move unexpectedly. Crushing and shearing injuries may be caused by the mechanism and safety edges of the gate.



- ▶ The emergency release lever must not be used during heavy storms or bad weather.
- ▶ First secure the gate against unexpected movement. Then you can use the emergency release lever.
- ▶ Keep persons and animals clear of the range of movement of the gate.

NOTE

- The emergency release is only suitable for opening or closing the gate in an emergency. For example, during a power failure or in the case of an operator malfunction.
The emergency release is not suitable for opening or closing the gate regularly. This could cause damage to the operator or gate.
- The clearance is reduced when the gate is opened with the emergency release lever. To prevent damage, keep an appropriate distance from the emergency release lever.



INFORMATION

- The gate can be unlocked in any gate position. It might be necessary to move the gate leaf slightly in order to engage it.

10. Operation

Unlocking the operator

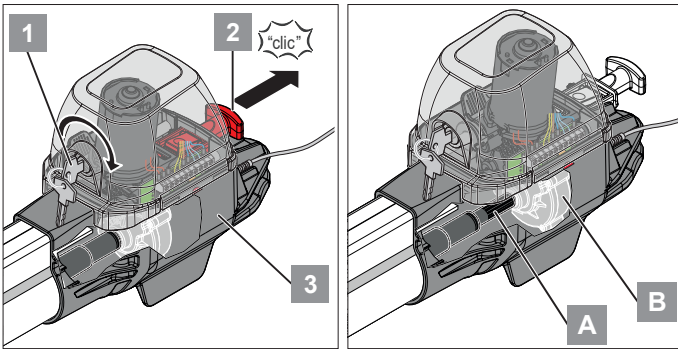

Fig. 1

Fig. 2

1. Insert key **(1)** and turn 35° to the right.
2. Pull the emergency release lever **(2)** away from the housing **(3)** until it locks into place.
To simplify unlocking: Move gate leaf manually.
 - ⇒ The operator is unlocked.
 - ⇒ The gate can now be moved by hand.

Locking the operator

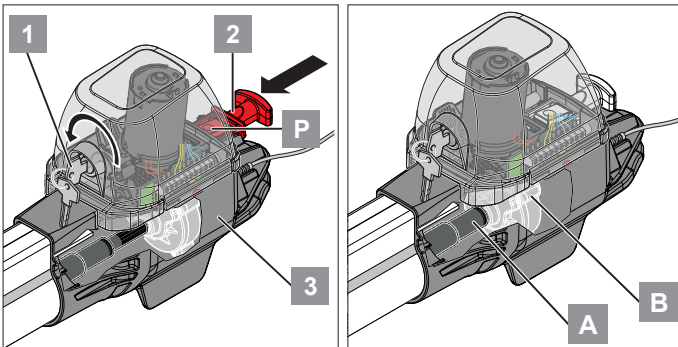

Fig. 1

Fig. 2

1. Press button **(P)** down and hold.
2. Move emergency release lever **(2)** towards housing **(3)**.
3. Insert key **(1)** and turn it 35° to the left.
 - ⇒ Operator is locked.
 - ⇒ The gate can now only be moved using the operator.

11. Maintenance and care

11.1 Important notes and information

Service the operator regularly as directed below. This ensures safe operation of your operator and a long service life. In particular, observe the warnings below.

DANGER



Danger if not observed!

If warnings are not observed, serious injury or death may result.

- ▶ All warnings must be complied with.
- ▶ In addition, observe the safety instructions in Chapter “2. General safety instructions” from page 9.



Danger due to electric current!

Contact with live parts may result in electric current flowing through the body.

- Electric shock, burns or death will result.
- ▶ All work on electrical components must be carried out by a **trained electrician**.
 - ▶ Before performing work on the operator, including the connection of accessories, it must be disconnected from the power supply.
 - ▶ If an accumulator is connected, disconnect it from the control unit.
 - ▶ Check that the operator is not live.
 - ▶ Secure the operator against being switched back on.

WARNING



Danger of crushing and shearing!

If the gate moves and there are persons or animals in the movement area, crushing and shearing injuries may be caused by the mechanism and safety edges of the gate.



- ▶ All danger zones must be visible during the entire gate operation.
- ▶ Always keep the moving gate in sight.
- ▶ Keep persons and animals clear of the range of movement of the gate.
- ▶ Never put your hand near the gate when it is moving or near moving parts.
- ▶ Do not drive through the gate until it has opened completely.
- ▶ You must have faults or defects repaired professionally without delay.



Danger due to hot parts!

In frequent operation, parts of the motor or the control unit may become hot. If the cover is removed and hot parts are touched, they may cause burns.

- ▶ Allow the operator to cool down before removing the cover.

NOTE

- Powerful sprays of water lead to damage to the control unit. Protect the control unit housing against powerful jets of water, e.g. from a garden hose.
- The use of unsuitable cleaning agents may damage the surface of the operator.
Clean the operator with a damp, lint-free cloth only.

11.2 Maintenance schedule

How often?	What?	How?
Once a month	• Check all safety devices	• qualified specialist , for correct functioning
	• Test obstacle detection	• qualified specialist , see Chapter “9.1 Checking the obstacle detection” on page 48
	• Check that the gate runs smoothly	• User , see chapter “4.3 Preparing for installation” on page 17
	• Test the emergency release	• User , see chapter “10.6 Function of the emergency release” on page 52
Once a year	• Test the gate and all moving parts	• qualified specialist , as directed by the manufacturer
	• Test the gate hinges	• user , check for smooth running, lubricate if necessary
	• Check the mounting bolts of the operator	• qualified specialist , check that bolts are tight and tighten if necessary
As needed	• Clean operator and fastenings	• user , with a damp, lint-free cloth
	• Clean the photocell	• User , see Chapter “11.3 Care” on page 55, section “Cleaning the photocell”
	• Check the control unit housing regularly for moisture and insects	• User , dry and clean

NOTE

- In the event of faults or if you have questions on maintenance and care, you **must** contact a **qualified specialist**.

11. Maintenance and care

11.3 Care

Cleaning the operator

1. Disconnect the operator from the mains voltage.
If an accumulator has been installed, remove the control unit cover and disconnect the accumulator from the control unit; see also Chapter “**5.2 Circuit board of the control unit**” from page 28.
Then check that the power is disconnected.
 2. Remove loose dirt with a moist, lint-free cloth:
 3. If required, follow the steps in reverse order to connect the accumulator.
Connect the operator to the mains voltage.
Check that the voltage supply is connected.
- ✓ **The operator is supplied with voltage.**

➔ **NOTE**

- Powerful sprays of water lead to damage to the control unit. Protect the control unit housing against powerful jets of water, e.g. from a garden hose.

Clean the photocell

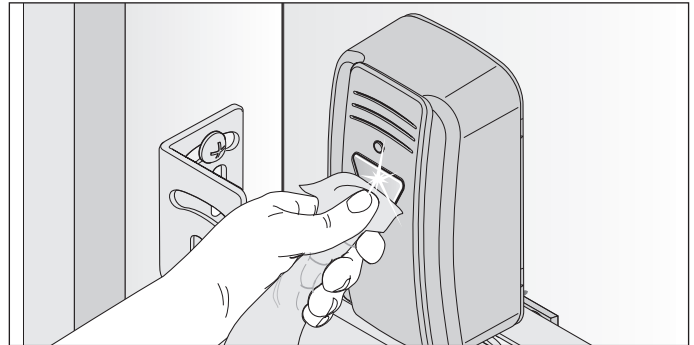

Fig. 1

➔ **NOTE**

- Do not change the position of the photocell when cleaning it.
1. Clean the housing and reflectors of the photocell with a damp, lint-free cloth.
 2. Check the mounting of the photocells.

12. Troubleshooting

12.1 Important notes and information

Observe the basic warnings listed below.

DANGER



Danger if not observed!

If warnings are not observed, serious injury or death may result.

- ▶ All warnings must be complied with.
- ▶ In addition, observe the safety instructions in Chapter “**2. General safety instructions**” from page 9.



Danger due to electric current!

Contact with live parts may result in electric current flowing through the body. Electric shock, burns or death will result.

- ▶ All work on electrical components must be carried out by a **trained electrician**.
- ▶ Before performing work on the operator, including the connection of accessories, it must be disconnected from the power supply.
- ▶ If an accumulator is connected, disconnect it from the control unit.
- ▶ Check that the operator is not live.
- ▶ Secure the operator against being switched back on.

NOTE

- If the gate is not in view and the radio remote control is actuated, objects in the movement area of the gate may be jammed and damaged. Objects must not be in the range of movement of the gate.

12.2 Preparing for troubleshooting

The following guide to troubleshooting lists potential problems and their causes and information on correcting them. In some cases, other chapters and sections with a more detailed description are referenced.

You will be prompted to call a **qualified specialist** if this is required. Work on the electrical system and live parts must be performed by a **trained electrician**.

1. Disconnect the operator from the mains voltage.
If an accumulator is used, it must also be disconnected, see Chapter “**7. Connections and functions of the control unit**”, in section “**Connecting an accumulator**” on page 42.
2. After working on the operator, if applicable, connect/fit the accumulator in reverse order.
3. Connect the operator to the mains voltage.
Check that the voltage supply is connected.
✓ The operator is supplied with mains voltage.

12. Troubleshooting

12.3 Troubleshooting table

Problem	Possible cause	Test/check	Remedy
Operators do not start.	Jumper was moved with programmed force values.	• “SH” LED blinks quickly? (yes).	<ul style="list-style-type: none"> Place jumper in previous position. Reset the control unit. Replug jumpers. Perform programming runs.
Walk-through gate cannot be opened with handheld transmitter.	Handheld transmitter button not programmed.		<ul style="list-style-type: none"> Program button.
Gate system moves unevenly.	A/B dimensions are unequal.		<ul style="list-style-type: none"> Change installation dimensions.
Operator stops at pillar.	A or B dimension not correct.	• Are the A/B dimensions correct? (no)	<ul style="list-style-type: none"> Adjust fastening of operator to post or pillar.
	Limit stop misaligned.	• Are the A/B dimensions correct? (yes)	<ul style="list-style-type: none"> Adjust limit stop.
Gate does not stop at an obstacle.	Gate in programming run.		<ul style="list-style-type: none"> After the programming run, the obstacle recognition responds.
	DIP switch 8 to “ON”.		<ul style="list-style-type: none"> Set DIP switch 8 to “OFF”.
	Force tolerance too high.		<ul style="list-style-type: none"> Reduce force tolerance.
Operator does not learn the force values.	DIP switch 8 to “OFF”.		<ul style="list-style-type: none"> Set DIP switch 8 to “ON”.
Closing sequence incorrect.	Operators incorrectly connected.		<ul style="list-style-type: none"> Connect operators as specified in the manual.
Gate remains stopped during opening.	Obstacle in light beam.	• Photocell interrupted (yes).	<ul style="list-style-type: none"> Remove obstacle.
	Photocell soiled.		<ul style="list-style-type: none"> Clean the photocell.
	Connection for external devices overloaded (terminal 9 +10).	• Photocell interrupted (no).	<ul style="list-style-type: none"> Observe maximum connection power.
	Voltage drop when operator starts.		<ul style="list-style-type: none"> Only connect suitable accessories.
The gate cannot be opened or closed with buttons or a handheld transmitter.	Range of the transmitter too short – weak battery.	• LED on the handheld transmitter lights up (yes).	<ul style="list-style-type: none"> Replace battery.
	Radio receiver defective.		<ul style="list-style-type: none"> Replace radio receiver.
	Handheld transmitter not programmed.		<ul style="list-style-type: none"> Program handheld transmitter.
	Poor reception.		<ul style="list-style-type: none"> Mount antenna externally, see “8.13 Antenna connections” on page 47.
	Incorrect radio frequency.		<ul style="list-style-type: none"> Check the radio frequency.
	Battery almost flat.	• LED on the handheld transmitter lights up (no).	<ul style="list-style-type: none"> Replace battery.
	Battery not inserted correctly.		<ul style="list-style-type: none"> Insert battery correctly.
	Handheld transmitter defective.		<ul style="list-style-type: none"> Replace the handheld transmitter.
	Radio receiver not properly plugged in.	• Does an LED on the radio receiver light up if a button on the handheld transmitter is pressed? (no)	<ul style="list-style-type: none"> Plug in radio receiver properly.
	Radio receiver defective.		<ul style="list-style-type: none"> Replace radio receiver.
	Radio receiver without power supply.		<ul style="list-style-type: none"> Replace radio receiver.
	Handheld transmitter not programmed.		<ul style="list-style-type: none"> Program handheld transmitter.
	Continuous signal pending.	• “Mains + OPEN/CLOSE” LEDs on? (yes).	<ul style="list-style-type: none"> Check pulse generator.
Pulse generator defective.	<ul style="list-style-type: none"> Replace defective pulse generator. 		
Photocell interrupted.*	• “Mains + Safety” LEDs on? (yes).	<ul style="list-style-type: none"> Remove the object interrupting the photocell. 	

12. Troubleshooting

Problem	Possible cause	Test/check	Remedy	
	Very powerful public address systems in hospitals or industrial areas interfere with the radio control system.	• Fault occurs intermittently or for a short time? (yes).	• Change radio frequency. • Contact fault reporting centre.	
	The control unit has stored faulty values (e.g. due to a short power failure).	• “SH” LED blinks quickly? (yes).	• Reset the control unit. • Reprogram the operator. • If not possible, call customer service.	
Gate does not open.	Gate leaf has sunk or become misaligned due to strong temperature variations (gate jams).	• “Mains” LED on? (yes).	• Fix misaligned gate leaves.	
	Motor hums but does not move.		• Switch gate system off immediately!	
	Motor or control unit defective.		• Call customer service.	
	The operator is unlocked.		• Lock the operator.	
	Cables have no contact.		• Check the cable connections.	
	Gate has frozen.		• Clear snow and ice from gate system.	
	Snow is blocking the movement zone of the gate.		• Clear snow.	
	Power failure No mains voltage.		• “Mains” LED on? (no).	• Check the connection. • Establish missing connection.
	Mains fuse defective.			• Check fuse. • Replace the fuse.
	Radio transmission faulty.		• Transmitter battery weak.	• Replace transmitter battery.
• Check range.		• Reduce distance.		
• Transmitter defective.		• Replace transmitter.		
Electric lock remains locked.	• Opening pulse is present.	• Check electric lock and connections. • Have electric lock replaced.		
Gate does not close.	Power failure No mains voltage.	• “Mains” LED on? (no).	• Check the connection. • Establish missing connection.	
	Mains fuse defective.		• Check fuse. • Replace the fuse.	
	Photocell triggered or defective.		• Remove obstacle. • Clean the lens. • Check alignment.	
	Radio transmission faulty.	• Transmitter battery weak.	• Replace transmitter battery.	
		• Check range.	• Reduce distance.	
		• Transmitter defective.	• Replace transmitter.	
Gate cannot be opened or closed with connected key switch.	Cable connections interrupted.	• “Mains + Start 1/Start 2” LEDs on? (yes).	• Tighten terminal.	
	Key switch defective.		• Replace key switch.	
	Permanent contact due to damaged wire insulation.		• Check wiring. • Replace damaged cables.	
	Pulse transmitter (key switch) defective.	• “Mains + Start 1/Start 2” LEDs on? (no).	• Check pulse transmitter (key switch). • Replace defective pulse transmitter (key switch).	
Gate does not open or close completely.	Limit stop incorrectly set.	• Gate stops before set end position? (yes)	• Set limit stop correctly.	
	Gate fitting not installed correctly.	• Gate stops before set end position? (no)	• Change the gate fitting.	

12. Troubleshooting

Problem	Possible cause	Test/check	Remedy
Gate remains stationary and reverses during opening or closing.	Obstacle recognition tripped.	• Obstacle in the movement range? (yes)	• Remove obstacle.
	Hinges stiff.	• Obstacle in the movement range? (no)	• Lubricate hinges.
	Post or pillar has changed.		• Align posts/pillars.
	Limit stop(s) misaligned.		• Adjust limit stop(s).
	Gate leaf/leaves unstable.	• Gate leaves swing during start-up? (yes)	• Reinforce gate leaves.
	Wind pressure too strong.	• Strong wind load? (yes)	• Open and close gate again.
Gate operation interrupted.	Power failure	• “Mains“ LED on? (no).	• Check fuse. • Replace the fuse.
	Renewed pulse by command device.	• Unintended operation	• Secure command device such as handheld transmitter
		• Faulty contact	• Have connections checked.
	Obstacle recognition detects an obstacle.	• with reversion	• Remove obstacle. • If gate is not running smoothly, have it repaired. • Observe wind load.
	Safety contact strip detects an obstacle	• with reversion	• Remove object from the gate travel path.
			• Check the function of the safety device
Photocell detects an obstacle.	• with reversion	• Remove object from the gate travel path. • Check the function of the safety device • Replace defective photocell.	

* If photocell is interrupted, the operator can be moved in dead man mode with the “Open” and “Close” buttons.
If an obstacle is detected, obstacle recognition also occurs in this operating mode.

13. Taking out of operation, disassembly, storage and disposal

13.1 Important notes and information

Disassembly of the operator may only be performed by a **qualified specialist**. In particular, observe the warnings below.

DANGER



Danger if not observed!

If warnings are not observed, serious injury or death may result.

- ▶ All warnings must be complied with.
- ▶ In addition, observe the safety instructions in Chapter “**2. General safety instructions**” from page 9.



Danger due to electric current!

Contact with live parts may result in electric current flowing through the body. Electric shock, burns or death will result.

- ▶ All disassembly work on electrical components must be carried out by a **trained electrician**.
- ▶ Disconnect the mains plug before disassembling the operator.
- ▶ If an accumulator is connected, disconnect it from the control unit.
- ▶ Check that the operator is not live.
- ▶ Secure the operator against being switched back on.

CAUTION



Risk of injury to hands!

Rough metal parts may cause abrasions and cuts when picked up or touched.

- ▶ You must wear your personal safety gloves when working with rough metal parts.



Risk of injury to feet!

Falling parts can cause serious foot injuries.

- ▶ Safety shoes must be worn when performing work on the gate.



13.2 Taking out of operation and disassembly

The operator and its accessories must be disconnected from the power supply when taking them out of operation or during disassembly.

1. Disconnect the control unit from the power supply. To do so, switch off the local main switch or the fuse. See Chapter “**4.7 Opening/closing the control unit housing**” on page 22. Then check that the power is disconnected.
2. If an accumulator was used, disconnect it; see also Chapter “**5.2 Circuit board of the control unit**” from page 28.
3. Disassembly is carried out in reverse order of installation.

13.3 Storage

NOTE

- Improper storage may damage the operator. The operator must be stored in closed and dry rooms.

Store the packaging units as follows:

- in enclosed, dry rooms in which they are protected against moisture
- at a storage temperature from $-20\text{ }^{\circ}\text{C}$ to $+70\text{ }^{\circ}\text{C}$
- leave room for unhindered passage

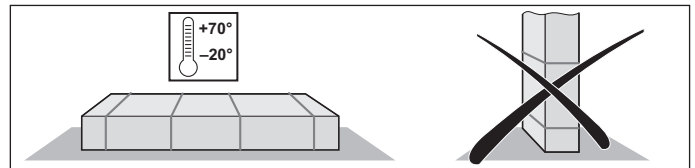

Fig. The operator should be stored horizontally

13. Taking out of operation, disassembly, storage and disposal

13.4 Disposal

WARNING



Danger caused by hazardous substances!

Improper storage, use or disposal of accumulators, batteries and operator components pose a risk to the health of humans and animals. Serious injury or death may result.

- ▶ Accumulators and batteries must be stored out of the reach of children and animals.
- ▶ Keep accumulators and batteries away from chemical, mechanical and thermal influences.
- ▶ Batteries may contain hazardous chemical substance which damage the environment and pose a risk to the health of humans and animals. Caution must be exercised, in particular when handling batteries containing lithium, as these can easily ignite and cause fires if not handled correctly.
- ▶ Batteries and accumulators in electrical appliances and which can be removed non-destructively must be disposed of separate from the appliance.



NOTE

- Dispose of all components in accordance with local and national regulations to avoid environmental damage.
- Wherever possible, avoid the production of waste. Please check before disposing of components whether it is possible to recycle them.



INFORMATION



This device is labelled in accordance with European Directive 2012/19/EU on used electrical and electronic devices (WEEE – waste electrical and electronic equipment).

This Directive provides the framework for the EU-wide return and recycling of used equipment.

Operator components that have been taken out of service as well as old accumulators and batteries must not be disposed of with household waste. Components which are no longer in use, old accumulators and batteries must be disposed of properly. You must observe the local and national regulations here. Contact your specialist retailer to find out more about current disposal channels.



14. Brief instructions for installation

The brief instructions do not replace the installation and operating manual.

Read this Installation and Operating Manual carefully and, most importantly, follow all warnings and safety instructions. This will ensure that you can install the product safely and optimally.

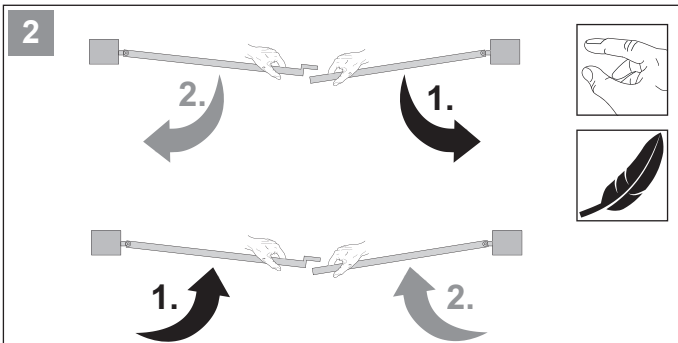
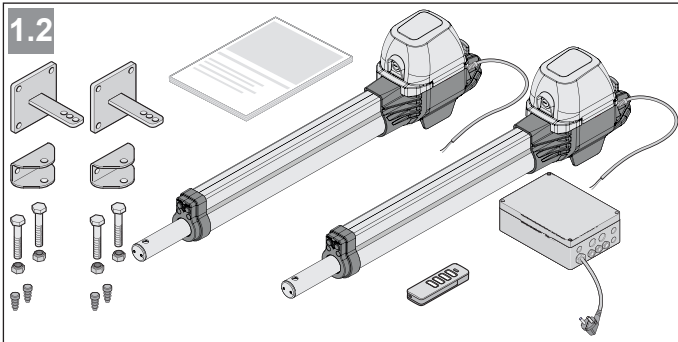
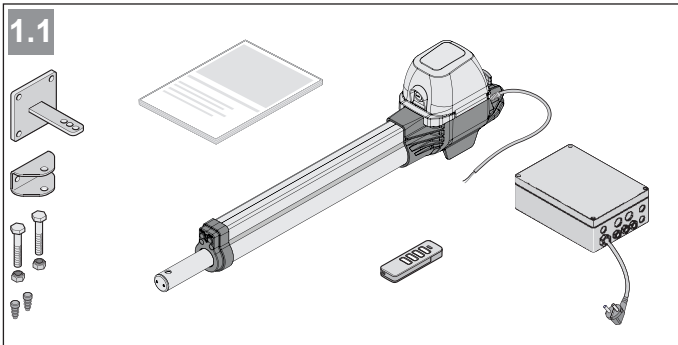
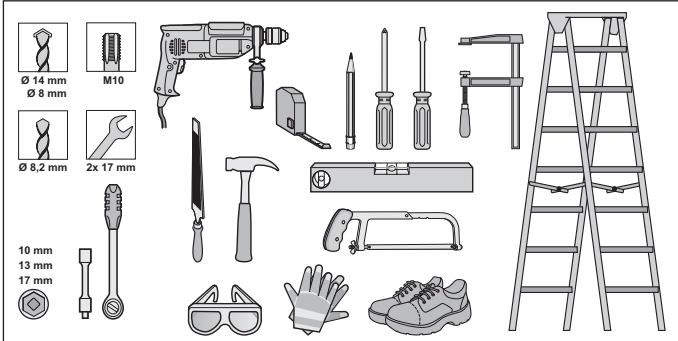

3

Example 90°

A	B	C	C1	D
80	104	216	1065	240
100	106	237	1086	261
120	108	258	1107	282
140	110	279	1129	304
160	112	300	1151	326

A = 80 mm **B = 154 mm** **C1 = 80 mm**

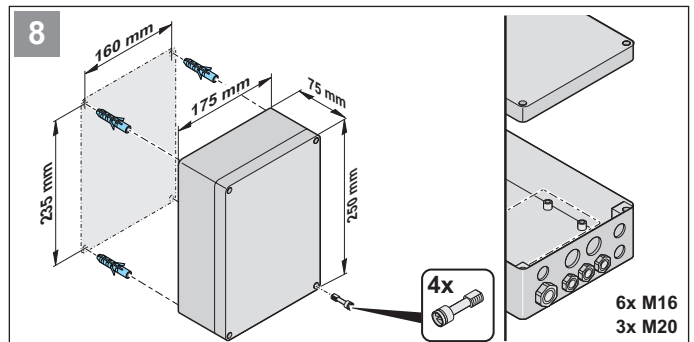
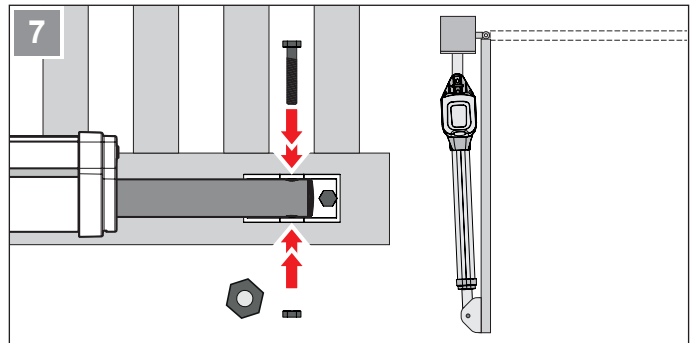
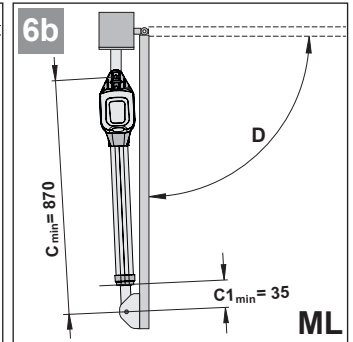
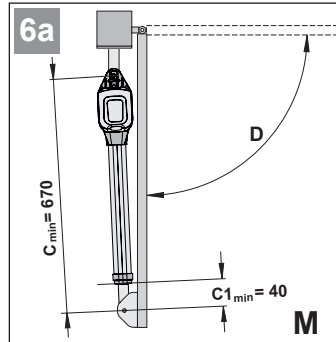
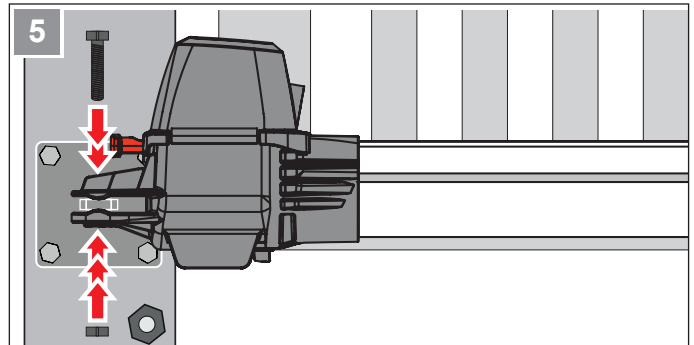
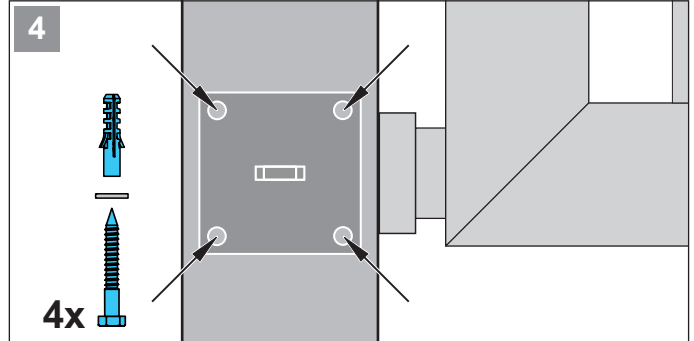

14. Brief instructions for installation

9 **10** **11** **12** **13** **14** **15** **16** **17** **18** **19** **20** **21** **22** **23** **24** **25**

2-FI.
1-FI.

24V
5 6 9 10 11 12
M1 M2 24V Warnlicht

M1 M2

24V 0V 24V Warn

Auf Zu SH Wl
Imp. Geh.
ON
1 2 3 4 5 6 7 8
T1A

M1 M2

1 2 3

A B

L and N 25 mm max. PE 50 mm max.

230V AC 1 2 3 4
L PE PE

1 2 "click" 3

A B

! !

14. Brief instructions for installation

26 open

27

28

29 close

30

31

32

33

34

35

36

37



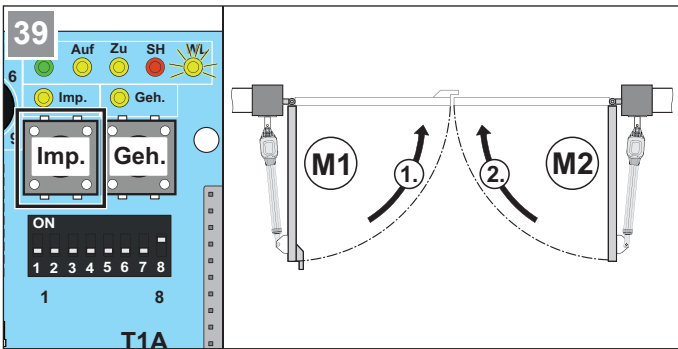
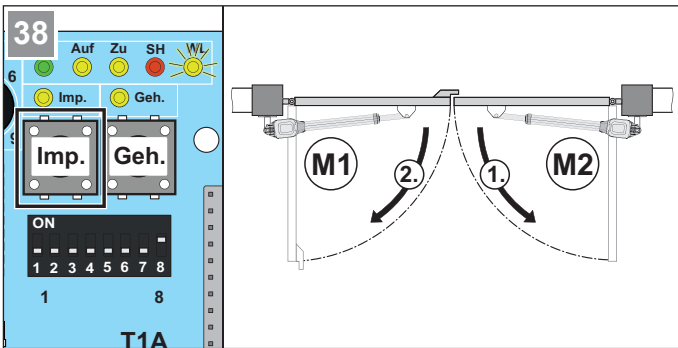











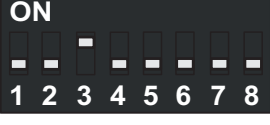

14. Brief instructions for installation

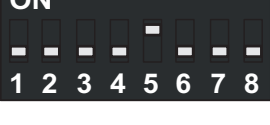

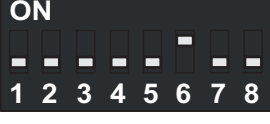
15. Connection diagrams and functions of the DIP switches

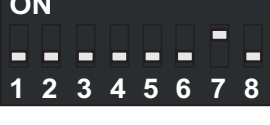
Overview of the setting options for the DIP switches

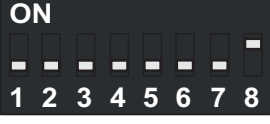
Do not use metal objects to set the DIP switches, because this may damage the DIP switches or the circuit board.

DIP switch	Function	Effect
1 	ON	Response to triggering the safety input (terminals 17 + 18) while the gate opens. • The gate stops
	OFF 	Response to triggering the safety input (terminals 17 + 18) while the gate opens. • No reaction
2 	ON	Response to triggering the safety input while the gate closes. • The gate stops
	OFF 	Response to triggering the safety input while the gate closes. • Gate reverses
3 	ON	DIP 2 = OFF • Gate opens completely
	OFF 	DIP 2 = OFF • Gate reverses
4 	ON	Warning light blinks
	OFF 	Warning light on
5 	ON	Pre-warning time warning light • 3 seconds • Warning light blinks or lights up before gate starts moving, depending on the position of DIP 4
	OFF 	Pre-warning time warning light • OFF
6* 	ON	Fully automatic closing function
	OFF 	Manual operation/semi-automatic closing
7* 	ON	Fully automatic closing function with shorter hold open time after drive-through of the photocell (depending on position of DIP 6). Semi-automatic closing function with shorter hold open time after drive-through of the photocell (depending on position of DIP 6). • 5 seconds
	OFF 	No function
8 	ON	Continuous operation/operator learns continuously while the gate opens and closes. • Force values – runtime – closing delay
	OFF 	Test mode • Operator does not learn any values • Setting the limit stops

8  **NOTE**
 Leave DIP switch 8 "ON" after a programming run.
 OFF position immediately deletes all saved values.

 Factory setting

* For additional settings, see TorMinal operating manual.

15. Connection diagrams and functions of the DIP switches

Connection diagram

twist M and twist ML

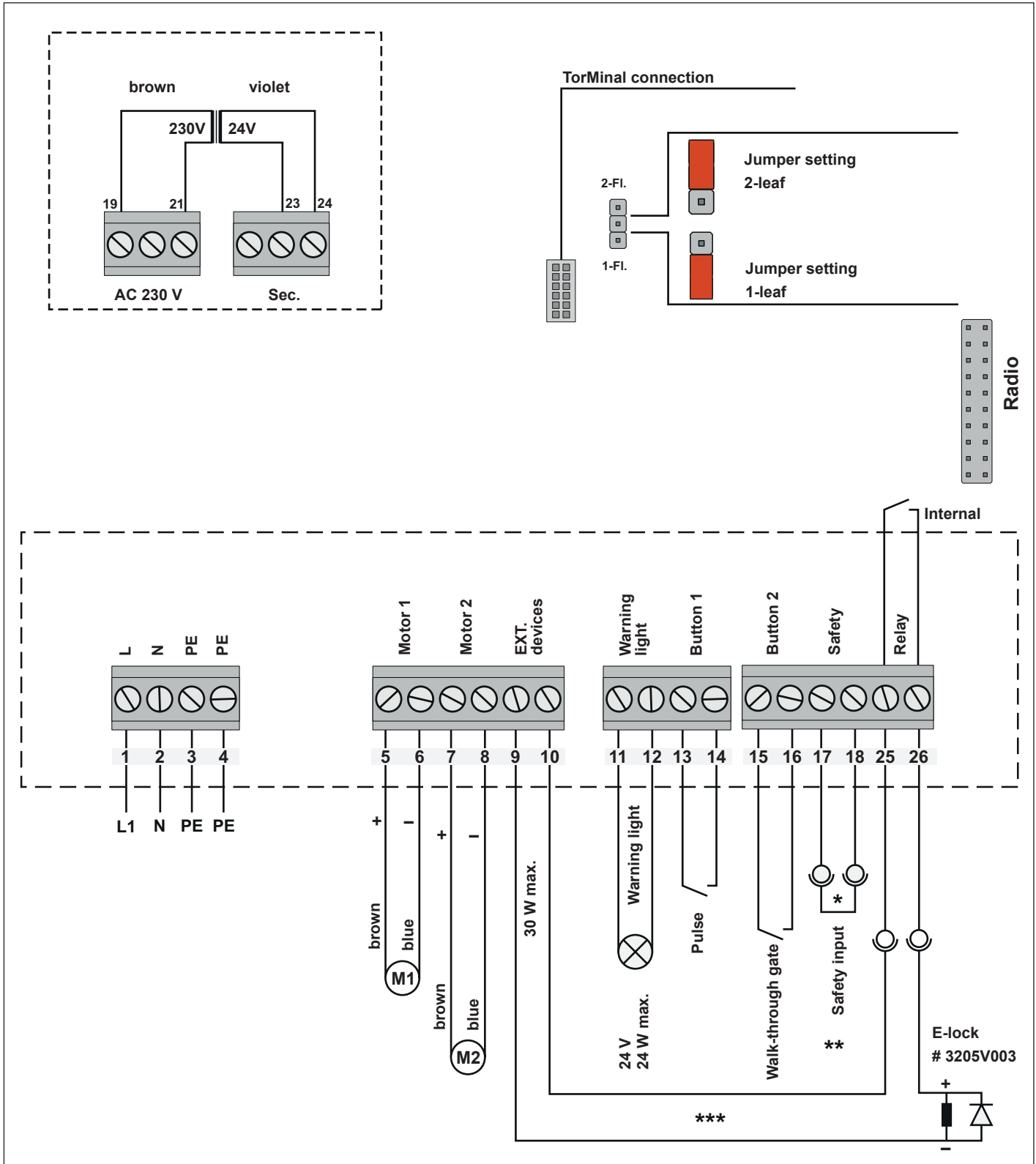

* Delivery status with wire jumper.

** Safety contact strip can only be connected with a separate evaluation unit.

*** Connection option for photocell and safety contact strip.

16. Declarations of Conformity

16.1 EC Declaration of Incorporation

Declaration of incorporation

for installation of an incomplete machine in accordance with the Machinery Directive 2006/42/EC, Annex II, Part 1 B

SOMMER Antriebs- und Funktechnik GmbH
Hans-Böckler-Straße 27
73230 Kirchheim/Teck
Germany

hereby declares that the swing gate operator
twist M / twist ML

have been developed, designed and manufactured in conformity with the:

- Machinery Directive 2006/42/EC
- Low Voltage Directive 2014/35/EU
- Electromagnetic Compatibility Directive 2014/30/EU
- RoHS Directive 2011/65/EU.

The following standards were applied:

EN ISO 13849-1, PL "C" Cat. 2	Safety of machines – Safety-related parts of controls. – Part 1: General design guidelines.
EN 60335-1, where applicable	Safety of electrical appliances/operators for doors.
EN 61000-6-2	Electromagnetic compatibility (EMC) – interference resistance.
EN 61000-6-3	Electromagnetic compatibility (EMC) – interference.
EN 60335-2-95	General safety requirements for household and similar electrical appliances. – Part 2: Particular requirements for operators for vertically moving garage doors for residential use.
EN 60335-2-103	General safety requirements for household and similar electrical appliances. – Part 2: Special requirements for operators for gates, doors and windows.

The following requirements of Annex 1 of the Machinery Directive 2006/42/EC are met: 1.1.2, 1.1.3, 1.1.5, 1.2.1, 1.2.2, 1.2.3, 1.2.4, 1.2.6, 1.3.2, 1.3.4, 1.3.7, 1.5.1, 1.5.4, 1.5.6, 1.5.14, 1.6.1, 1.6.2, 1.6.3, 1.7.1, 1.7.3, 1.7.4

The special technical documentation was prepared in accordance with Annex VII Part B and will be submitted to regulators electronically on request.

- in combination with door types in the reference list, which can be found under Certifications:

www.sommer.eu

The incomplete machine is intended solely for installation in a door system to form a complete machine as defined by the Machinery Directive 2006/42/EC. The door system may only be put into operation after it has been established that the complete system complies with the EC Directives listed above.

The undersigned is responsible for compilation of the technical documents.

Kirchheim/Teck,
20.12.2022



i.V. 

Jochen Lude
Responsible for documents

16.2 Simplified EU Declaration of Conformity for radio systems

SOMMER Antriebs- und Funktechnik GmbH hereby declares that the radio system (twist M/twist ML) complies with Directive 2014/53/EU. The full text of the EU Declaration of Conformity for the radio system can be found at:



<https://som4.me/mrl>

16. Declarations of Conformity

16.3 UKCA declaration of incorporation

SOMMER Antriebs- und Funktechnik GmbH
 Hans-Böckler-Straße 27
 73230 Kirchheim/Teck
 Germany

hereby declares that the products designated below, have been developed, designed and manufactured in conformity with the:

- Supply of Machinery (Safety) Regulations 2008
- Electrical Equipment (Safety) Regulations 2016
- Electromagnetic Compatibility Regulations 2016
- The Restriction of the Use of Certain Hazardous Substances in Electrical and Electronic Equipment Regulations 2012

The machine component must not be put into service until it has been established that the machine into which the machine component is to be incorporated complies with the provisions of the Supply of Machinery (Safety) Regulations 2008.

The following standards were applied:

- BS EN ISO 13849-1, PL "C" Cat. 2 Safety of machinery. Safety-related parts of control systems. General principles for design.
 – Part 1: General principles for design.
- BS EN 60335-1+A15 where applicable Household and similar electrical appliances. Safety. General requirements.
- BS EN IEC 61000-6-2 Electromagnetic compatibility (EMC). Generic standards. Immunity standard for industrial environments.
- BS EN IEC 61000-6-3 Electromagnetic compatibility (EMC). Generic standards. Emission standard.
- BS EN 60335-2-95 + A2 Household and similar electrical appliances. Safety.
 – Part 2: Particular requirements for drives for vertically moving garage doors for residential use.
- BS EN 60335-2-103 Household and similar electrical appliances. Safety.
 – Part 2: Particular requirements for drives for gates, doors and windows.

Product type	Products
Swing gate operator	twist M / twist ML

The following requirements of Annex 1 of the Supply of Machinery (Safety) Regulations 2008 are met:
 1.1.2, 1.1.3, 1.1.5, 1.2.1, 1.2.2, 1.2.3, 1.2.4, 1.2.5, 1.2.6, 1.3.1, 1.3.2, 1.3.4, 1.3.7, 1.5.1, 1.5.4, 1.5.6, 1.5.14, 1.6.1, 1.6.2, 1.6.3, 1.7.1, 1.7.3, 1.7.4

The special technical documentation was prepared in accordance with Annex VII Part B and will be submitted to regulators electronically on request.

The product may only be used in combination with door types in the reference list, which can be found under Certifications at www.sommer.eu

The products are imported into the United Kingdom by:

SOMMER Doco
 Unit B3 Elvington Industrial Estate
 Elvington
 York
 YO41 4AR

Kirchheim/Teck,
 20.12.2022



i.V.

Jochen Lude
 Responsible for documents

16.4 UKCA declaration of conformity for radio systems

SOMMER Antriebs- und Funktechnik GmbH
 Hans-Böckler-Straße 27
 73230 Kirchheim/Teck
 Germany

hereby declares that the products designated below, when used as intended, comply with the essential requirements of the Radio Equipment Regulations 2017 and that, in addition, the standards listed below have been applied.

- | | |
|-----------------------------------|---------|
| DIN VDE 0620-1 (where applicable) | 2016-01 |
| EN 62368-1:2016-05 + AC:2015 | 2016-05 |
| EN 62479:2011 | 2011-09 |
| ETSI EN 300 220-2 V3.1.1 | |
| ETSI EN 300 328 V2.2.2 | |
| ETSI EN 301 489-1 V2.2.2 | 2019-11 |
| ETSI EN 301 489-3 V2.1.1 | 2019-03 |

Product type	Products
Swing gate operator	twist M / twist ML

The products are imported into the United Kingdom by:

SOMMER Doco
 Unit B3 Elvington Industrial Estate
 Elvington
 York
 YO41 4AR

Kirchheim/Teck,
 20.12.2022



i.V.

Jochen Lude
 Responsible for documents

SOMMER Antriebs- und Funktechnik GmbH

Hans-Böckler-Straße 27
73230 Kirchheim/Teck
Germany

www.sommer.eu

© Copyright 2023 All rights reserved.